



International Baccalaureate®  
Baccalauréat International  
Bachillerato Internacional

# Physics

## Higher and Standard level

Specimen papers 1, 2 and 3

For first examinations in 2016

# CONTENTS

**Physics higher level paper 1 specimen question paper**

**Physics higher level paper 1 specimen markscheme**

**Physics higher level paper 2 specimen question paper**

**Physics higher level paper 2 specimen markscheme**

**Physics higher level paper 3 specimen question paper**

**Physics higher level paper 3 specimen markscheme**

**Physics standard level paper 1 specimen question paper**

**Physics standard level paper 1 specimen markscheme**

**Physics standard level paper 2 specimen question paper**

**Physics standard level paper 2 specimen markscheme**

**Physics standard level paper 3 specimen question paper**

**Physics standard level paper 3 specimen markscheme**



**PHYSICS  
HIGHER LEVEL  
PAPER 1**

SPECIMEN PAPER

1 hour

---

INSTRUCTIONS TO CANDIDATES

- Do not open this examination paper until instructed to do so.
- Answer all the questions.
- For each question, choose the answer you consider to be the best and indicate your choice on the answer sheet provided.
- A clean copy of the **Physics Data Booklet** is required for this paper.
- The maximum mark for this examination paper is [40 marks].

1. A cube has sides of length  $10(\pm 1)$  mm. What is the percentage uncertainty in the volume of the cube?
- A. 1%
  - B. 3%
  - C. 10%
  - D. 30%
2. A toy car accelerates from rest down an inclined track at  $2.0 \text{ ms}^{-2}$ . What is the speed of the car after 3.0 s?
- A.  $6.0 \text{ ms}^{-1}$
  - B.  $9.0 \text{ ms}^{-1}$
  - C.  $45 \text{ ms}^{-1}$
  - D.  $54 \text{ ms}^{-1}$
3. A parachutist jumps out of an aircraft and falls freely for a short time, before opening his parachute. Which graph shows the variation of the acceleration  $a$  with time  $t$  of the parachutist from the time he leaves the aircraft until after the parachute is completely open?

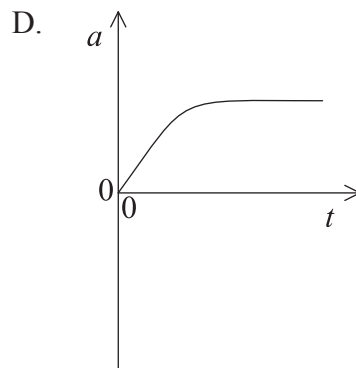
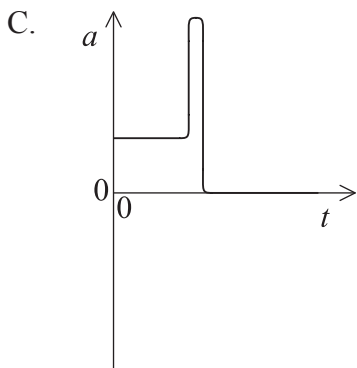
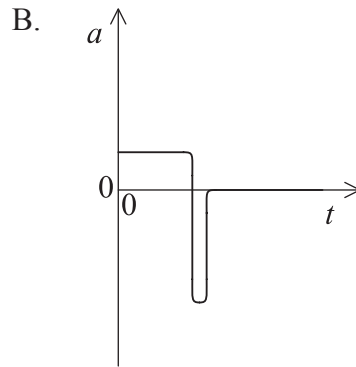
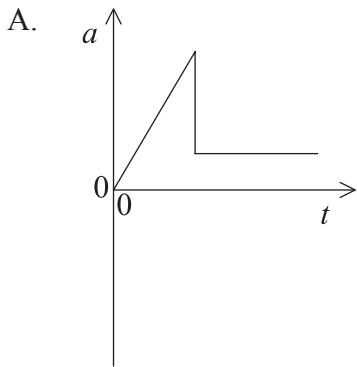

4. An object of mass  $m$  slides with acceleration  $a$  down a plane which makes an angle  $\theta$  with the horizontal.

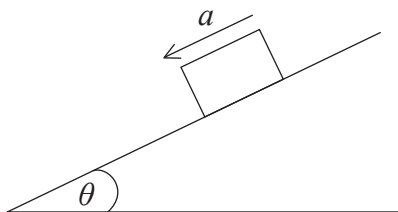

The acceleration of free-fall is  $g$ . What is the frictional force between the object and the plane?

- A.  $m(g - a)$
- B.  $m(a \sin \theta + g)$
- C.  $m(g \sin \theta + a)$
- D.  $m(g \sin \theta - a)$
5. A mass hangs freely from the end of a spring. A student raises the mass vertically until the tension in the spring becomes zero. The gain in gravitational potential energy of the mass is equal to the work done
- A. by the student against the force of gravity acting on the mass.
- B. on the mass by the student plus the elastic potential energy lost by the spring.
- C. on the mass by the student minus the elastic potential energy lost by the spring.
- D. on the mass by the student minus the work done on the mass by the tension in the spring.

6. An object of mass  $m$  moving with velocity  $u$  collides with and sticks to an identical stationary object. Immediately after the collision the combined object moves with velocity  $v$ . What will be the loss of kinetic energy?

- A.  $\frac{1}{4}mu^2$
- B.  $\frac{1}{4}mv^2$
- C.  $\frac{1}{2}mv^2$
- D.  $\frac{1}{4}m(v-u)^2$

7. A car is driven along a straight horizontal track. The car's engine produces a constant driving force. The car starts from rest and the effects of friction and air resistance are negligible. Which graph represents the variation with time  $t$  of the power  $P$  developed by the engine?

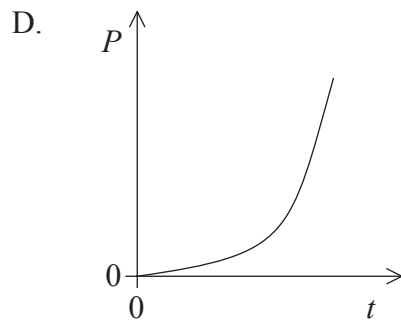
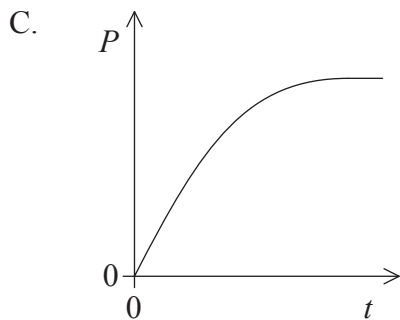
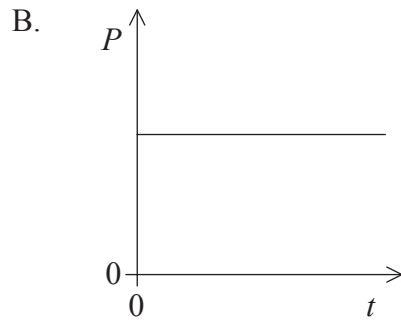
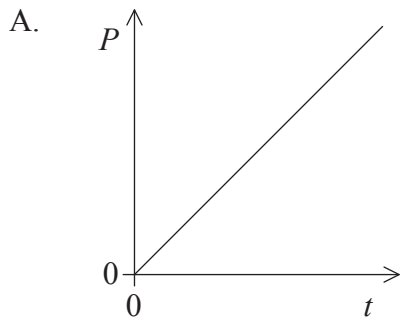

8. An electrical heater of power 12 W is immersed in a liquid of mass 0.2 kg. The graph shows the variation of the temperature  $\theta$  of the liquid with time  $t$ .

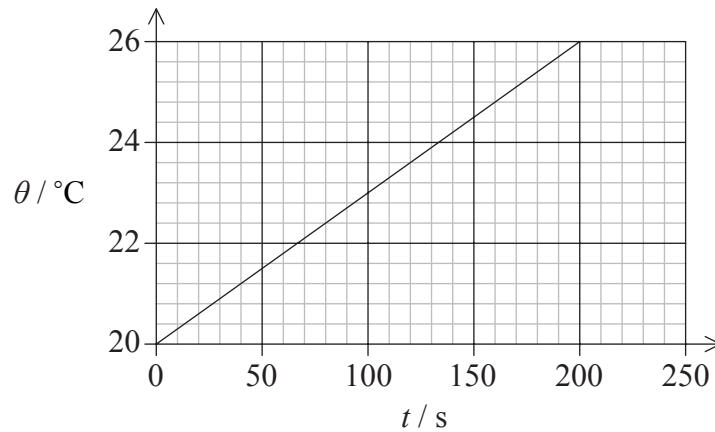

What is the value for the specific heat capacity of the liquid?

- A.  $20 \text{ J kg}^{-1} \text{ K}^{-1}$
  - B.  $500 \text{ J kg}^{-1} \text{ K}^{-1}$
  - C.  $2000 \text{ J kg}^{-1} \text{ K}^{-1}$
  - D.  $12\,000 \text{ J kg}^{-1} \text{ K}^{-1}$
9. Why is wave-particle duality used in describing the properties of light?
- A. Light is both a wave and a particle.
  - B. Both wave and particle models can explain all the properties of light.
  - C. Different properties of light can be more clearly explained by using one of the wave or particle models.
  - D. Scientists feel more confident when using more than one model to explain a phenomenon.

10. Two separate sealed containers hold air at the same temperature. They are connected by a thin tube containing a valve. Initially one container holds  $0.2\text{ m}^3$  of air at a pressure of  $50\text{ kPa}$  and the other container holds  $0.3\text{ m}^3$  of air at a pressure of  $20\text{ kPa}$ .

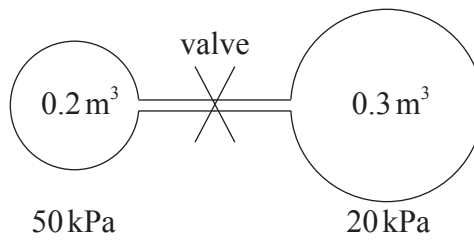

The valve is slowly opened and the temperature stays constant. What is the final pressure in the containers?

- A.  $32\text{ kPa}$
- B.  $35\text{ kPa}$
- C.  $38\text{ kPa}$
- D.  $70\text{ kPa}$
11. In simple harmonic motion, the velocity leads the displacement by a phase angle  $\phi$ . What is the value of  $\phi$ ?
- A. Zero
- B.  $\frac{\pi}{4}$
- C.  $\frac{\pi}{2}$
- D.  $\pi$



12. Which of the following, if any, will be transferred in the direction of propagation of a sound wave as it passes through the air?
- A. Mass only
  - B. Energy only
  - C. Both mass and energy
  - D. Neither mass nor energy
13. Some of the properties that can be demonstrated using waves are
- I. refraction
  - II. polarization
  - III. diffraction.

Which properties can be demonstrated using **sound** waves?

- A. I and II only
  - B. I and III only
  - C. II only
  - D. III only
14. A standing wave is produced by the superposition of two travelling waves. Which statement is **not** correct?
- A. The travelling waves must have the same frequency.
  - B. The travelling waves must have equal but opposite velocities.
  - C. In the standing wave, all the oscillating particles have the same amplitude.
  - D. In the standing wave, particles between adjacent nodes vibrate in phase.

15. In a particular lightning flash a charge of 15 C flows in a time of 0.5 ms. What is the average current?
- A. 33  $\mu$ A  
 B. 7.5 mA  
 C. 30 A  
 D. 30 kA
16. A heating coil is connected to a battery of electromotive force (emf) 10 V and negligible internal resistance. The power dissipated in the coil is 25 W. What is the resistance of the coil?
- A. 0.25  $\Omega$   
 B. 2.5  $\Omega$   
 C. 4.0  $\Omega$   
 D. 250  $\Omega$
17. Two identical cells, each of emf 1.6 V and internal resistance 2.0  $\Omega$ , are connected in parallel with a 3.0  $\Omega$  resistor.

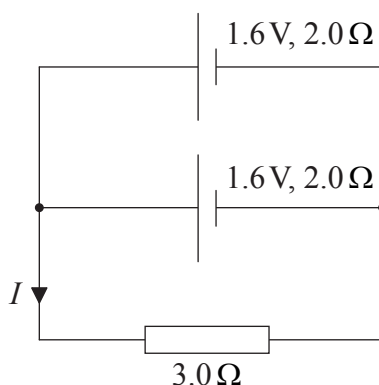

What is the current  $I$ ?

- A. 0.4 A  
 B. 0.6 A  
 C. 0.8 A  
 D. 1.6 A

18. The magnetic flux density  $B$  along the axis of a magnet is measured with distance  $x$  from the end of the magnet. The graph shows how  $\log B$  varies with  $\log x$ .

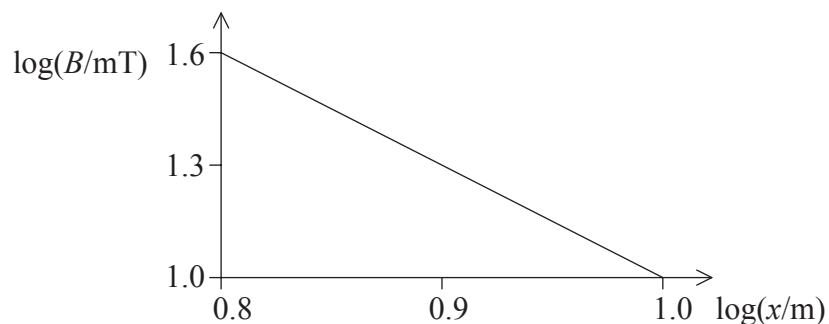

$B$  is proportional to which power of  $x$ ?

- A.  $-3$
  - B.  $-1.6$
  - C.  $1.6$
  - D.  $3$
19. An astronaut orbits the Earth in a space capsule. Which statement is correct?
- A. There are no gravitational forces acting on the space capsule or the astronaut.
  - B. The space capsule and the astronaut each have the same acceleration.
  - C. The space capsule and the astronaut are each in equilibrium.
  - D. The gravitational force on the space capsule is equal to that on the astronaut.

20. The table shows four of the energy levels for the hydrogen atom with their corresponding energies.

| Energy level | Energy / $10^{-19}$ J |
|--------------|-----------------------|
| 6            | –0.6                  |
| 4            | –1.4                  |
| 2            | –5.4                  |
| 1            | –21.8                 |

When an electron changes from level 6 to level 1 the spectral line emitted has a wavelength of  $9.4 \times 10^{-8}$  m. What is the approximate wavelength of the spectral line emitted when an electron changes from level 4 to level 2?

- A.  $5 \times 10^{-4}$  m
- B.  $5 \times 10^{-7}$  m
- C.  $5 \times 10^{-8}$  m
- D.  $5 \times 10^{-10}$  m
21. The magnitude of the binding energy per nucleon is
- A. a maximum for nuclides having nucleon numbers around 60.
- B. directly proportional to the neutron to proton ratio of nuclides.
- C. a maximum for nuclides with high nuclear charges.
- D. a maximum for nuclides with low nuclear charges.

22. A positive pion is a meson consisting of an up quark and an anti-down quark. A student suggests that the decay of the positive pion is represented by the following equation.

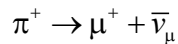

The suggestion is incorrect because one of the quantities is not conserved. Which quantity is **not** conserved in the student's equation?

- A. Charge
  - B. Baryon number
  - C. Lepton number
  - D. Strangeness
23. The Sankey diagram shows a typical fossil-fuel plant of total efficiency 40%. There are frictional, electrical transmission and energy losses to the lower temperature surroundings. Which branch represents energy losses to the surroundings?

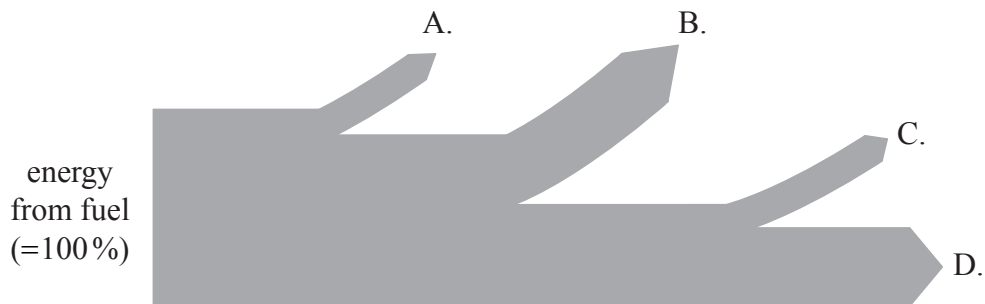

24. The absolute temperature of a black body increases by 2%. What is the percentage increase in the power emitted by the black body?
- A. 2
  - B. 4
  - C. 8
  - D. 16

25. What is thermal conduction mainly due to in a gas?

- A. The motion of free electrons
- B. Fast molecules transferring energy to slower molecules
- C. Slow molecules transferring energy to faster molecules
- D. Lattice vibrations causing collisions with neighbouring molecules

26. A single, narrow slit is illuminated by a parallel beam of monochromatic light and the image is projected onto a screen. Which graph shows how the intensity  $I$  of the diffracted light varies horizontally across the screen?

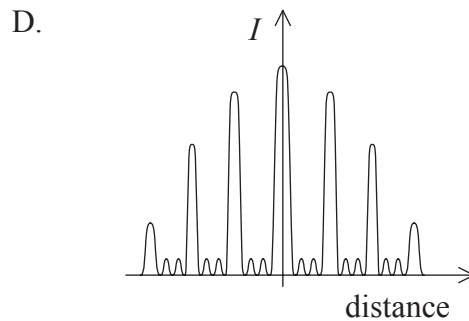
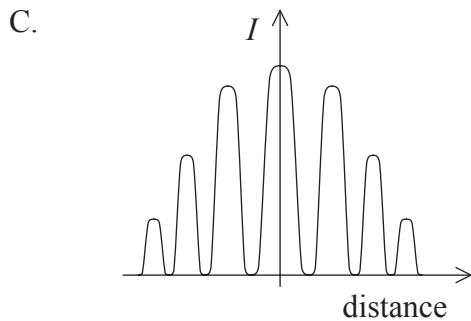
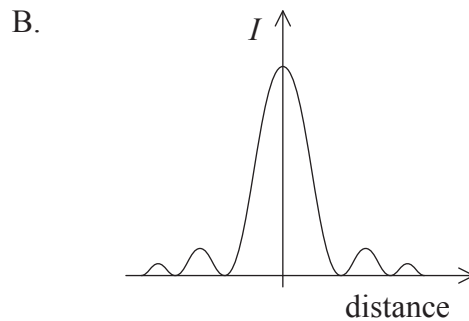
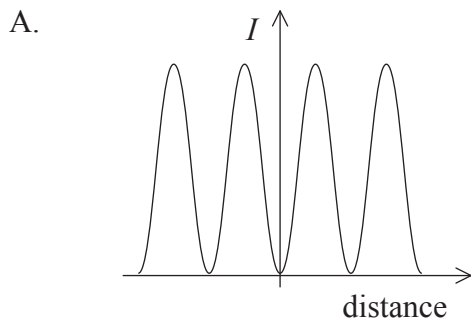

27. In a double-slit experiment using monochromatic light, a fringe pattern is formed on screen. A decrease in which of the following will increase the separation of the fringes?

- A. Wavelength of the light
- B. Distance between the slits and the screen
- C. Separation of the slits
- D. Intensity of the light source

28. In a particular optical microscope, which colour of light is likely to produce the best resolution in the final image?
- A. Yellow
  - B. Red
  - C. Green
  - D. Blue

29. A source emits sound of frequency 500 Hz. The source approaches a stationary observer at  $30 \text{ m s}^{-1}$ . The speed of sound is  $330 \text{ m s}^{-1}$ . What is the frequency of the sound detected by the observer?
- A. 460 Hz
  - B. 500 Hz
  - C. 530 Hz
  - D. 550 Hz

30. Which diagram shows the equipotential lines between a pair of parallel charged conductors?

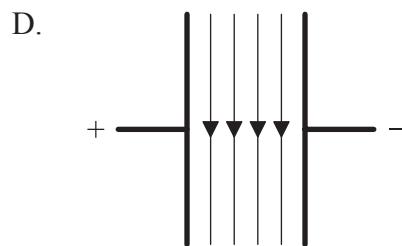
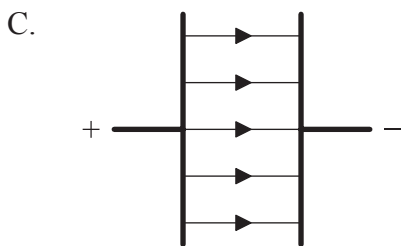
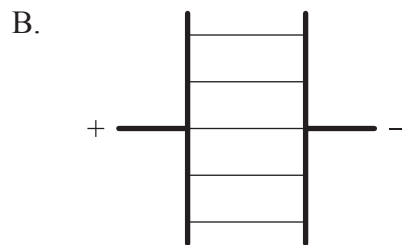
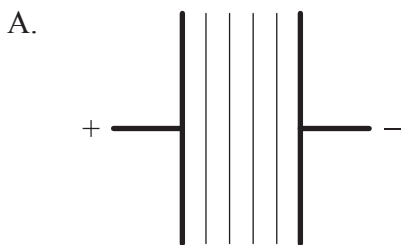

31. What is the correct quantity and unit for electric potential?

|    | Quantity | Unit             |
|----|----------|------------------|
| A. | vector   | $\text{Vm}^{-1}$ |
| B. | vector   | V                |
| C. | scalar   | $\text{Vm}^{-1}$ |
| D. | scalar   | V                |

32. The escape speed on a planet of mass  $M$  and radius  $r$  is  $v$ . What is the escape speed on a planet of mass  $2M$  and radius  $\frac{r}{2}$ ?

- A.  $\frac{v}{2}$
- B.  $v$
- C.  $2v$
- D.  $4v$

33. The gravitational field close to the surface of a planet is uniform. The gravitational potential difference between the surface of the planet and a point 30.0m above is  $15\text{Jkg}^{-1}$ . What is the work done in raising a mass of 4.0kg from the surface to a point 10.0m above the surface?

- A. 5J
- B. 10J
- C. 20J
- D. 80J



34. Lenz's law relates to electromagnetic induction. This law is a consequence of the conservation of which physical quantity?

- A. Momentum
- B. Energy
- C. Charge
- D. Current

35. Which diode bridge is used to produce full-wave rectification of an alternating voltage so that P is positive and Q is negative?

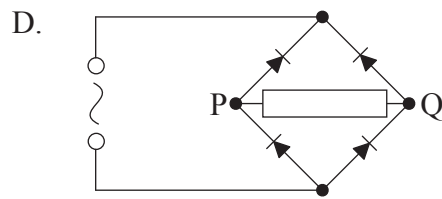
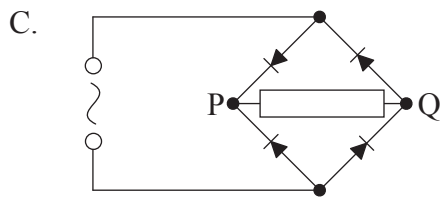
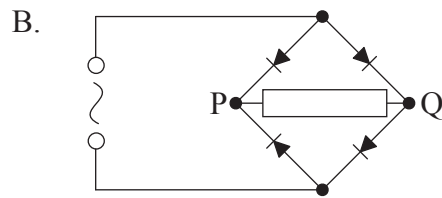
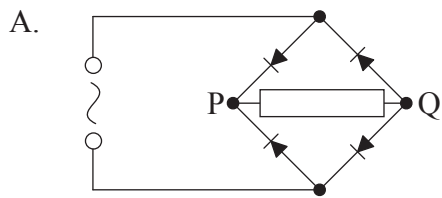

36. The circuit shown is used to charge a capacitor  $C$  through a resistor  $R$ .

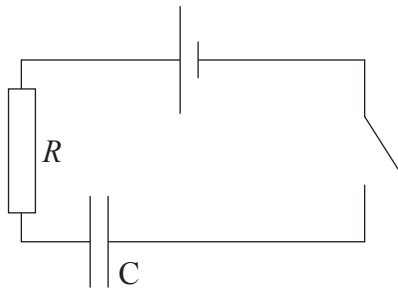

Which set of graphs correspond to the variation with time  $t$  of potential difference  $V$  across the capacitor and the current  $I$ , in the circuit, from the time that the switch is closed?

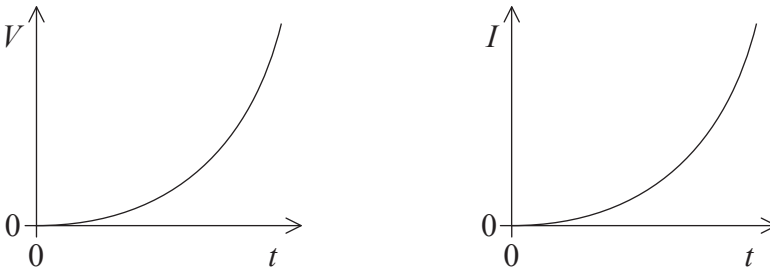
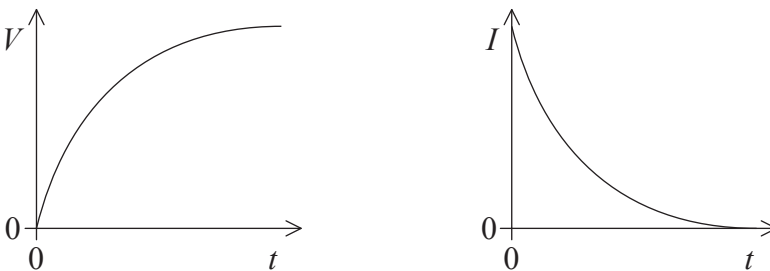
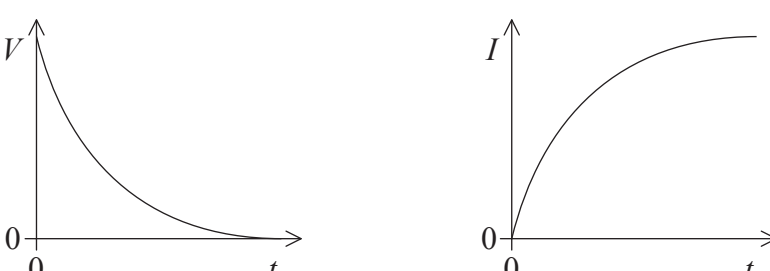
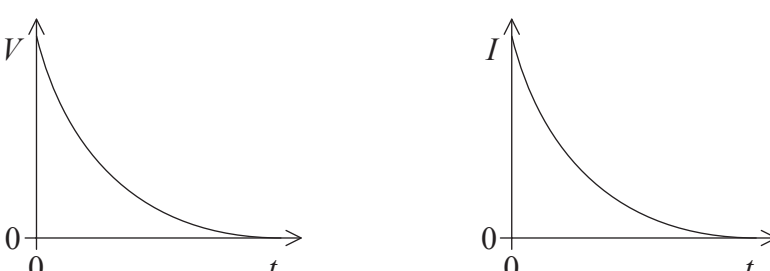
- A. 
- B. 
- C. 
- D. 

37. The work function of a metal is equal to the
- A. greatest energy with which an electron can be ejected from the surface by photoelectric emission.
  - B. least energy with which an electron can be ejected from the surface by photoelectric emission.
  - C. difference between the energy of a photon incident on the surface and the energy of the least energetic electron ejected.
  - D. difference between the energy of a photon incident on the surface and the energy of the most energetic electron ejected.
38. The density of the material in the nucleus of an atom
- A. is constant.
  - B. depends on the total number of nucleons in the nucleus.
  - C. depends only on the number of protons in the nucleus.
  - D. depends only on the number of neutrons in the nucleus.
39. A narrow beam of electrons passes through a thin crystalline film in an evacuated tube. A series of rings appears on a fluorescent screen at the end of the tube. What phenomenon within the film explains this observation?
- A. Emission of X-rays
  - B. Diffraction of electrons
  - C. Scattering of electrons
  - D. Ejection of neutrons
40. In radioactive  $\beta$  decay,  $\beta$  particles are emitted with a continuous spectrum of energies. This is because
- A. nuclei emitting  $\beta$  particles do not have discrete energy levels.
  - B. during a particular energy change, multiple  $\beta$  particles of differing energies are emitted.
  - C. during energy changes  $\beta$  particles share the energy with neutrinos.
  - D.  $\beta$  particle decay is always accompanied by the emission of  $\gamma$ -ray photons.
-





# **MARKSCHEME**

## **SPECIMEN PAPER 2016**

### **PHYSICS**

#### **Higher Level**

#### **Paper 1**

- |     |          |     |          |     |          |     |          |
|-----|----------|-----|----------|-----|----------|-----|----------|
| 1.  | <u>D</u> | 16. | <u>C</u> | 31. | <u>D</u> | 46. | <u>-</u> |
| 2.  | <u>A</u> | 17. | <u>A</u> | 32. | <u>C</u> | 47. | <u>-</u> |
| 3.  | <u>B</u> | 18. | <u>A</u> | 33. | <u>C</u> | 48. | <u>-</u> |
| 4.  | <u>D</u> | 19. | <u>B</u> | 34. | <u>B</u> | 49. | <u>-</u> |
| 5.  | <u>B</u> | 20. | <u>B</u> | 35. | <u>A</u> | 50. | <u>-</u> |
| 6.  | <u>A</u> | 21. | <u>A</u> | 36. | <u>B</u> | 51. | <u>-</u> |
| 7.  | <u>A</u> | 22. | <u>C</u> | 37. | <u>D</u> | 52. | <u>-</u> |
| 8.  | <u>C</u> | 23. | <u>B</u> | 38. | <u>A</u> | 53. | <u>-</u> |
| 9.  | <u>C</u> | 24. | <u>C</u> | 39. | <u>B</u> | 54. | <u>-</u> |
| 10. | <u>A</u> | 25. | <u>B</u> | 40. | <u>C</u> | 55. | <u>-</u> |
| 11. | <u>C</u> | 26. | <u>B</u> | 41. | <u>-</u> | 56. | <u>-</u> |
| 12. | <u>B</u> | 27. | <u>C</u> | 42. | <u>-</u> | 57. | <u>-</u> |
| 13. | <u>B</u> | 28. | <u>D</u> | 43. | <u>-</u> | 58. | <u>-</u> |
| 14. | <u>C</u> | 29. | <u>D</u> | 44. | <u>-</u> | 59. | <u>-</u> |
| 15. | <u>D</u> | 30. | <u>A</u> | 45. | <u>-</u> | 60. | <u>-</u> |

**PHYSICS  
HIGHER LEVEL  
PAPER 2**

Candidate session number

|  |  |  |  |  |  |  |  |  |  |
|--|--|--|--|--|--|--|--|--|--|
|  |  |  |  |  |  |  |  |  |  |
|--|--|--|--|--|--|--|--|--|--|

SPECIMEN PAPER

2 hours 15 minutes

Examination code

|  |  |  |  |  |  |  |  |
|--|--|--|--|--|--|--|--|
|  |  |  |  |  |  |  |  |
|--|--|--|--|--|--|--|--|

## INSTRUCTIONS TO CANDIDATES

- Write your session number in the boxes above.
- Do not open this examination paper until instructed to do so.
- Answer all questions.
- Write your answers in the boxes provided.
- A calculator is required for this paper.
- A clean copy of the **Physics Data Booklet** is required for this paper.
- The maximum mark for this examination paper is [95 marks].



Answer **all** questions. Write your answers in the boxes provided.

1. In the drop tower shown, containers with experiments inside of them are fired upwards inside a vertical tower.

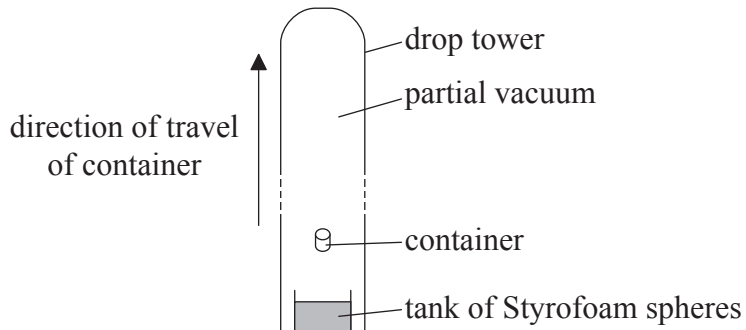

The container moves under the influence of gravity and eventually falls back to the bottom of the tower. Most of the air is removed from the tower so that air resistance is negligible. While in flight, the container and its contents are in free-fall.

- (a) The container is fired vertically upwards with initial speed  $48 \text{ m s}^{-1}$ . Determine the time that the container is in flight. [2]

.....

.....

.....

.....

.....

.....

(This question continues on the following page)





*(Question 1 continued)*

- (b) At the end of the flight, the container of total mass 480 kg falls into a tank of expanded Styrofoam (polystyrene) spheres to slow it. The container stops after moving a distance of 8.0 m in the Styrofoam. Calculate the average force that acts on the container due to the spheres. [3]

.....

.....

.....

.....

.....

.....

- (c) Outline why the experiments inside the container could be considered to be in “weightless” conditions. [2]

.....

.....

.....

.....

*(This question continues on the following page)*



*(Question 1 continued)*

(d) The tower is 120m high with an internal diameter of 3.5 m. When most of the air has been removed, the pressure in the tower is 0.96 Pa.

(i) Determine the number of molecules of air in the tower when the temperature of the air is 300 K. [3]

.....

.....

.....

.....

.....

.....

(ii) Outline whether the behaviour of the remaining air in the tower approximates to that of an ideal gas. [2]

.....

.....

.....

.....

*(This question continues on the following page)*



(Question 1 continued)

- (e) The container can also be released from rest at the top of the tower. The graph shows how the container velocity varies with time from release with the tower in a partial vacuum.

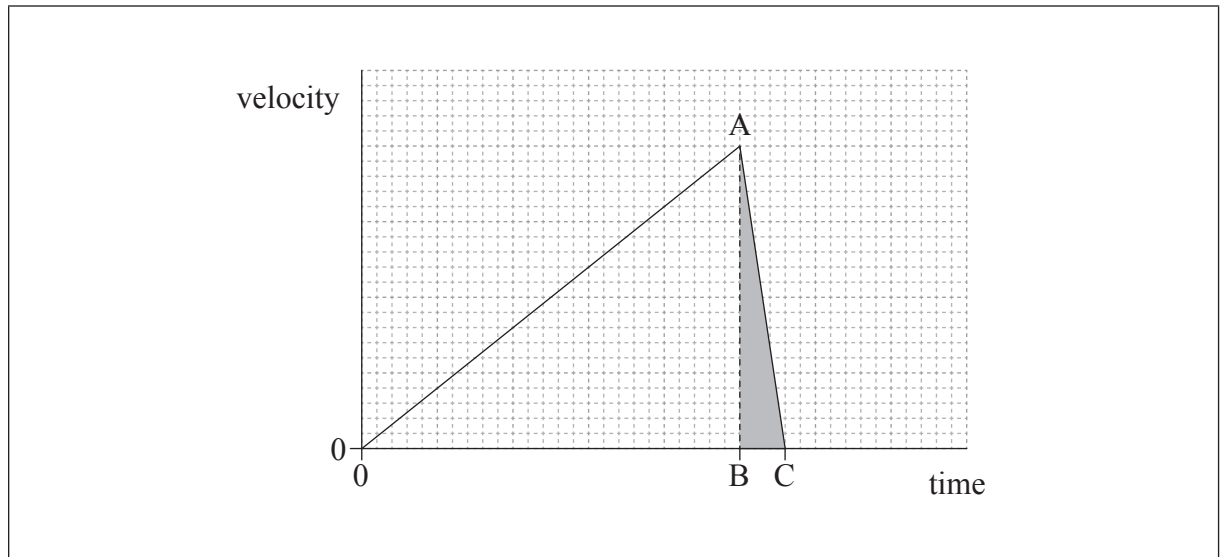

- (i) State the quantity that is represented by the shaded area ABC. [1]

.....

- (ii) Air is introduced into the tower. The container is released from the top of the tower when the air in the tower is at atmospheric pressure. Using the axes in (e), sketch a graph to show how the container velocity varies with time from release when the air is at atmospheric pressure. [3]



2. The diagram shows an electrical circuit with the values of its components. The cells have a negligible internal resistance.

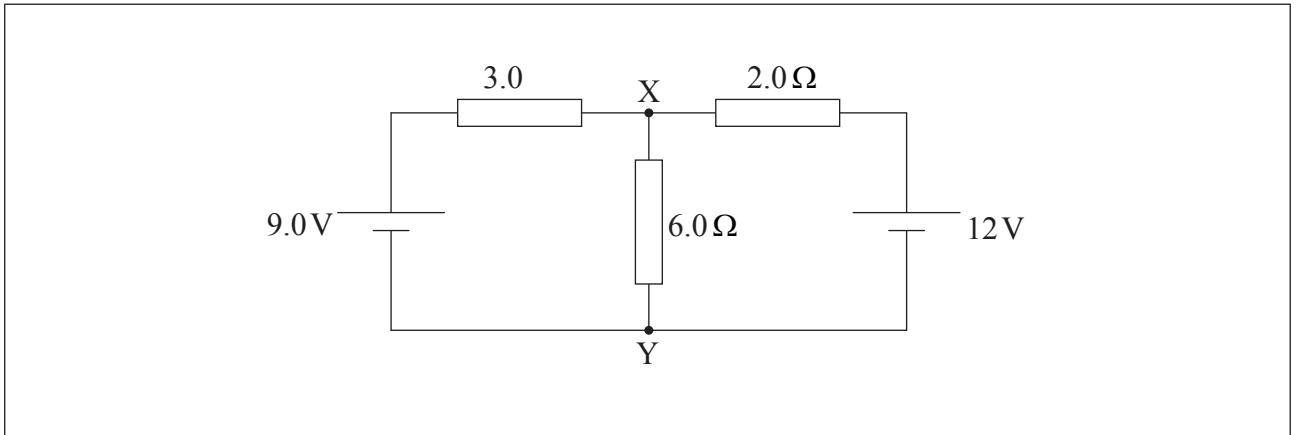

- (a) Show, using Kirchhoff's laws, that the current in the  $6.0\ \Omega$  resistor is 1.5 A. [4]

.....

.....

.....

.....

.....

.....

.....

.....

.....

*(This question continues on the following page)*



*(Question 2 continued)*

- (b) (i) Calculate the potential difference between X and Y. [1]

.....

.....

- (ii) Outline whether X **or** Y is at higher potential. [1]

.....

.....

.....



3. A circuit is designed to supply regular pulses of charge to a  $3.3\text{ k}\Omega$  resistor using an electronic switch S.

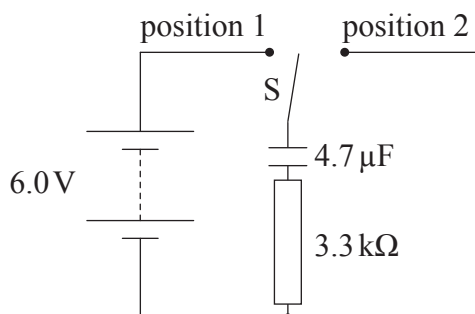

Initially the capacitor is uncharged. The battery has a negligible internal resistance. The capacitance of the capacitor is  $4.7\ \mu\text{F}$ .

- (a) At time  $t=0$  the switch is moved to position 1. Using the axes, draw a graph to show how the potential difference  $V$  across the capacitor varies with time  $t$  as it charges. A time scale is not required.

[2]

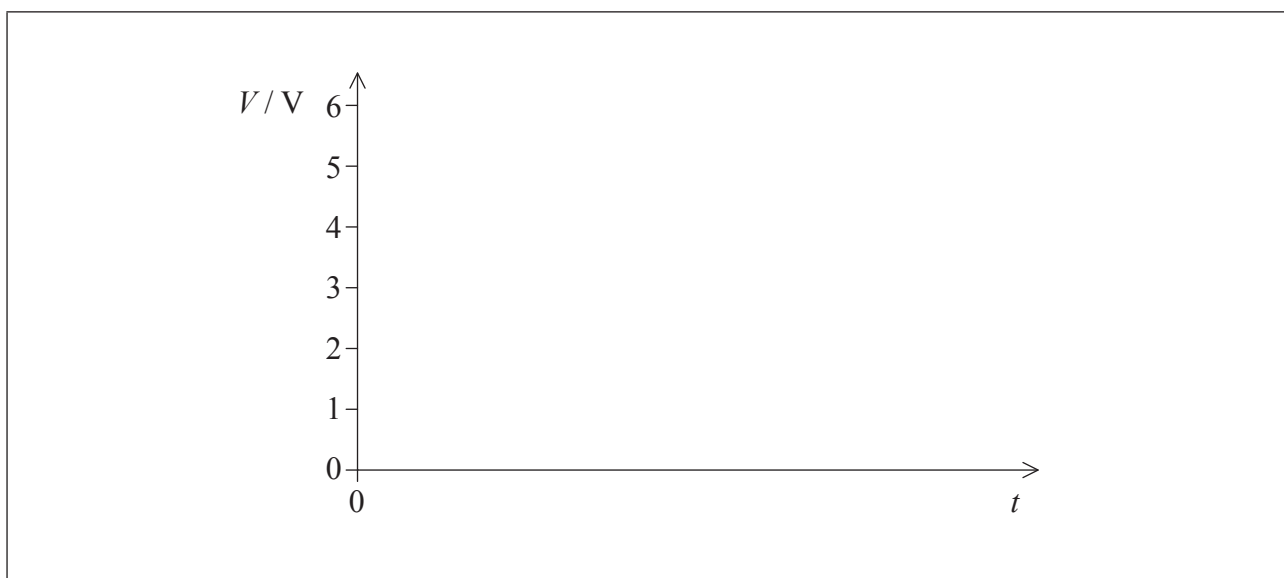

(This question continues on the following page)



(Question 3 continued)

(b) A single pulse of charge is produced by moving the switch S to position 2 for 6.3 ms.

(i) Show that the potential difference across the capacitor falls by about 2 V during the duration of the pulse. [3]

.....

.....

.....

.....

.....

.....

(ii) Calculate the charge that flows through the circuit during the pulse. [2]

.....

.....

.....

.....

(iii) The battery has a charge capacity of 0.55 Ah and the circuit produces one pulse each second. Calculate the time, in years, for which the battery can operate the circuit. [2]

.....

.....

.....

.....

(This question continues on the following page)



(Question 3 continued)

- (iv) Two batteries in series, each of emf 6.0 V and having negligible internal resistance, replace the single battery. All other components in the circuit remain the same. Compare the energy transferred from the two batteries with the energy transferred from the single battery during one charge–discharge cycle. [2]

.....

.....

.....

.....

- 4. A loudspeaker emits sound waves of a single frequency towards a reflecting barrier.

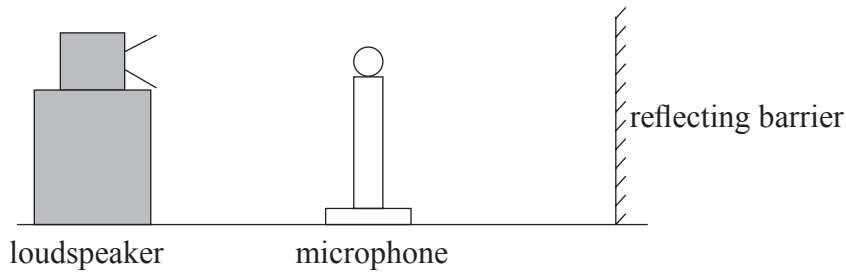

A microphone is moved along a straight line between the loudspeaker and the barrier. A sequence of equally spaced maxima and minima of sound wave intensity is detected.

- (a) Explain how the maxima and minima are formed. [4]

.....

.....

.....

.....

.....

.....

(This question continues on the following page)





*(Question 4 continued)*

(b) The microphone is moved through 1.0m from one point of minimum intensity to another point of minimum intensity. It passes through seven points of maximum intensity as it moves. The speed of sound is  $340\text{ m s}^{-1}$ .

(i) Calculate the wavelength of the sound waves. [2]

.....  
.....  
.....  
.....

(ii) Outline how you could use this arrangement to determine the speed of sound in air. [3]

.....  
.....  
.....  
.....  
.....  
.....  
.....  
.....



5. (a) A power station burns natural gas at a rate of  $35 \text{ kg s}^{-1}$ . The power output of the station is  $750 \text{ MW}$  and the efficiency of the station is  $38\%$ .

(i) Calculate the energy provided by the natural gas each second. [1]

.....  
.....  
.....  
.....

(ii) Calculate the specific energy of the natural gas. State appropriate units for your answer. [3]

.....  
.....  
.....  
.....

(b) Outline why much of the world's energy is provided from fossil fuels. [2]

.....  
.....  
.....  
.....

*(This question continues on the following page)*



*(Question 5 continued)*

(c) There is a suggestion that the temperature of the Earth may increase if the use of fossil fuels is not reduced over the coming years.

(i) Explain, with reference to the enhanced greenhouse effect, why this temperature increase may occur. [3]

.....

.....

.....

.....

.....

.....

.....

.....

.....

(ii) Outline how scientists continue to attempt to resolve the climate change debate. [1]

.....

.....

.....

.....

*(This question continues on the following page)*



(Question 5 continued)

- (d) Nuclear power stations are one way in which energy can be generated without the use of fossil fuels. One example of a nuclear fission reaction is as shown.

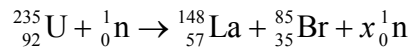

- (i) Identify the value of  $x$ . [1]

.....

- (ii) The following data are available.

Mass of U-235 = 235.044 u  
Mass of n = 1.009 u  
Mass of La-148 = 148.932 u  
Mass of Br-85 = 84.910 u

Determine, in MeV, the energy released when one uranium nucleus undergoes nuclear fission in the reaction in (d). [3]

.....  
.....  
.....  
.....  
.....  
.....

*(This question continues on the following page)*



*(Question 5 continued)*

- (iii) Outline, with reference to the speed of the neutrons, the role of the moderator in a nuclear reactor.

[3]

.....

.....

.....

.....

.....

.....



6. In 1798, Cavendish investigated Newton's law of gravitation by measuring the gravitational force between two lead spheres.

(a) State Newton's law of gravitation.

[2]

.....  
.....  
.....  
.....

(b) A student repeats the experiment with modern apparatus that has lead spheres of unequal size.

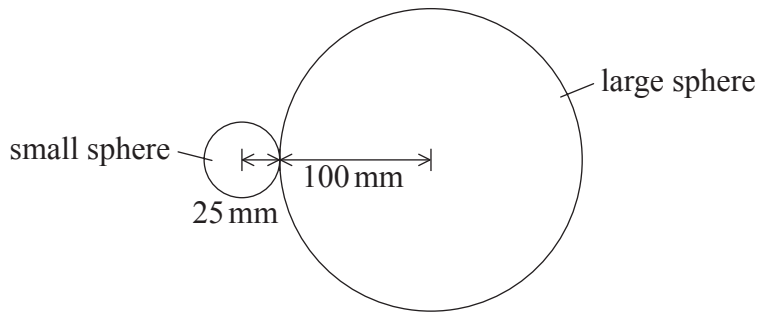

(not to scale)

The large sphere had a radius of 100 mm and a mass of 47 kg. The small sphere had a radius of 25 mm and a mass of 0.73 kg.

(i) Estimate the gravitational force between the spheres when the spheres were in contact.

[2]

.....  
.....  
.....  
.....

*(This question continues on the following page)*



*(Question 6 continued)*

- (ii) The student repeats Cavendish’s experiment using lead spheres with twice the radius. Discuss the effect on your calculation in (b)(i) of doubling the radius of both spheres. [4]

.....

.....

.....

.....

.....

.....

- (c) In Cavendish’s original experiment, the large sphere was part of an isochronous pendulum. State what is meant by isochronous. [1]

.....

.....



7. A magnet is suspended on the end of a spring and oscillates vertically with a small amplitude above a coil.

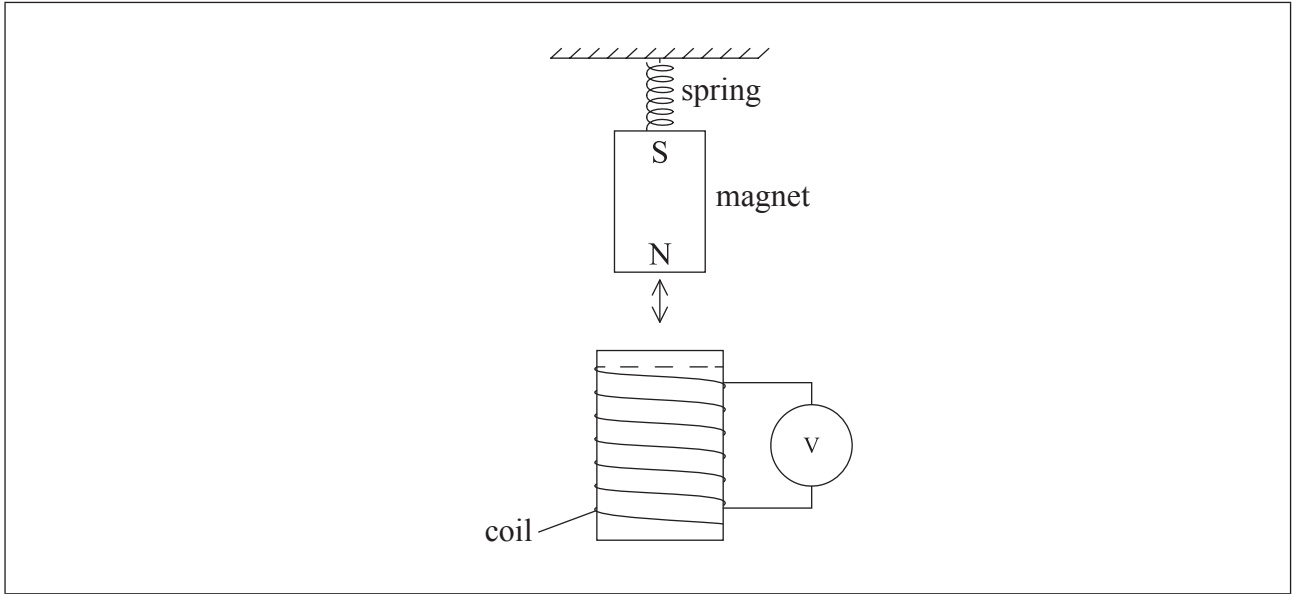

The coil has 240 turns each with a cross-sectional area of  $2.5 \times 10^{-4} \text{ m}^2$ .

The graph shows how the magnetic flux density  $B$  through the coil varies with time  $t$  for one complete oscillation of the magnet. The magnet is at its equilibrium position when  $t=0$ .

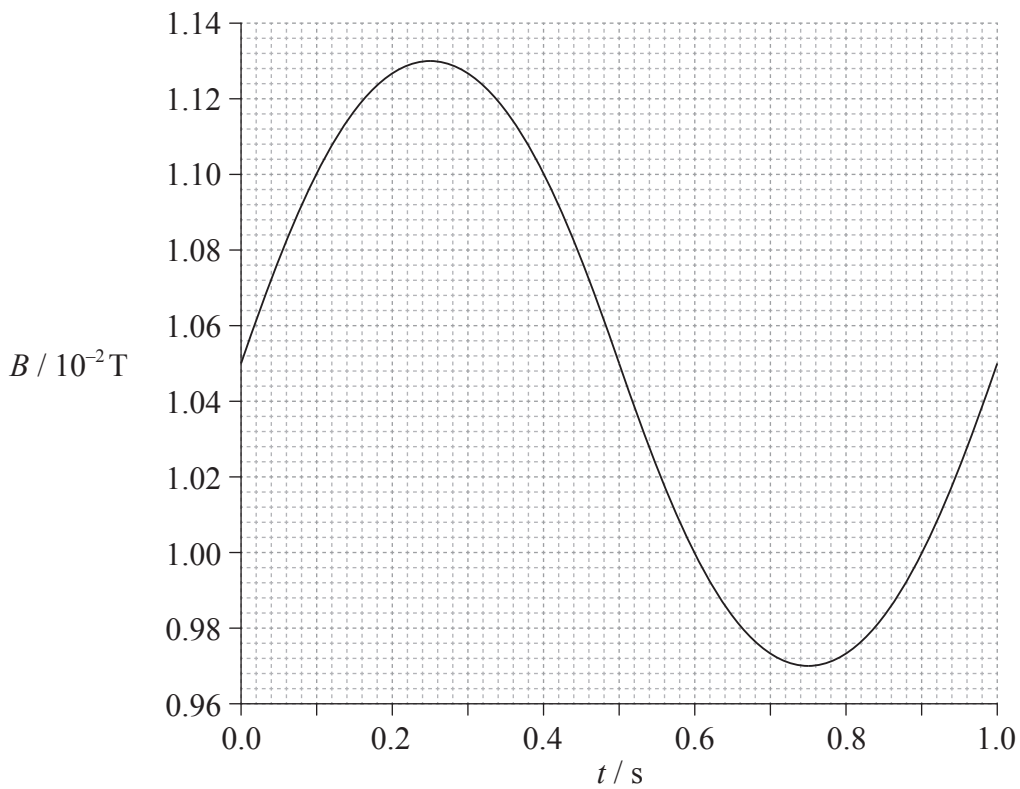

(This question continues on the following page)





(Question 7 continued)

- (a) Determine the maximum electromotive force (emf) induced in the coil.

[4]

- (b) The spring is changed so that the frequency of oscillation of the magnet is doubled without changing the amplitude of oscillation. Using the axes, sketch a graph to show how the induced emf in the coil varies with time  $t$  when the frequency of oscillation has doubled. The coil is at its equilibrium position when  $t=0$ . You should give suitable values on the  $y$ -axis.

[3]

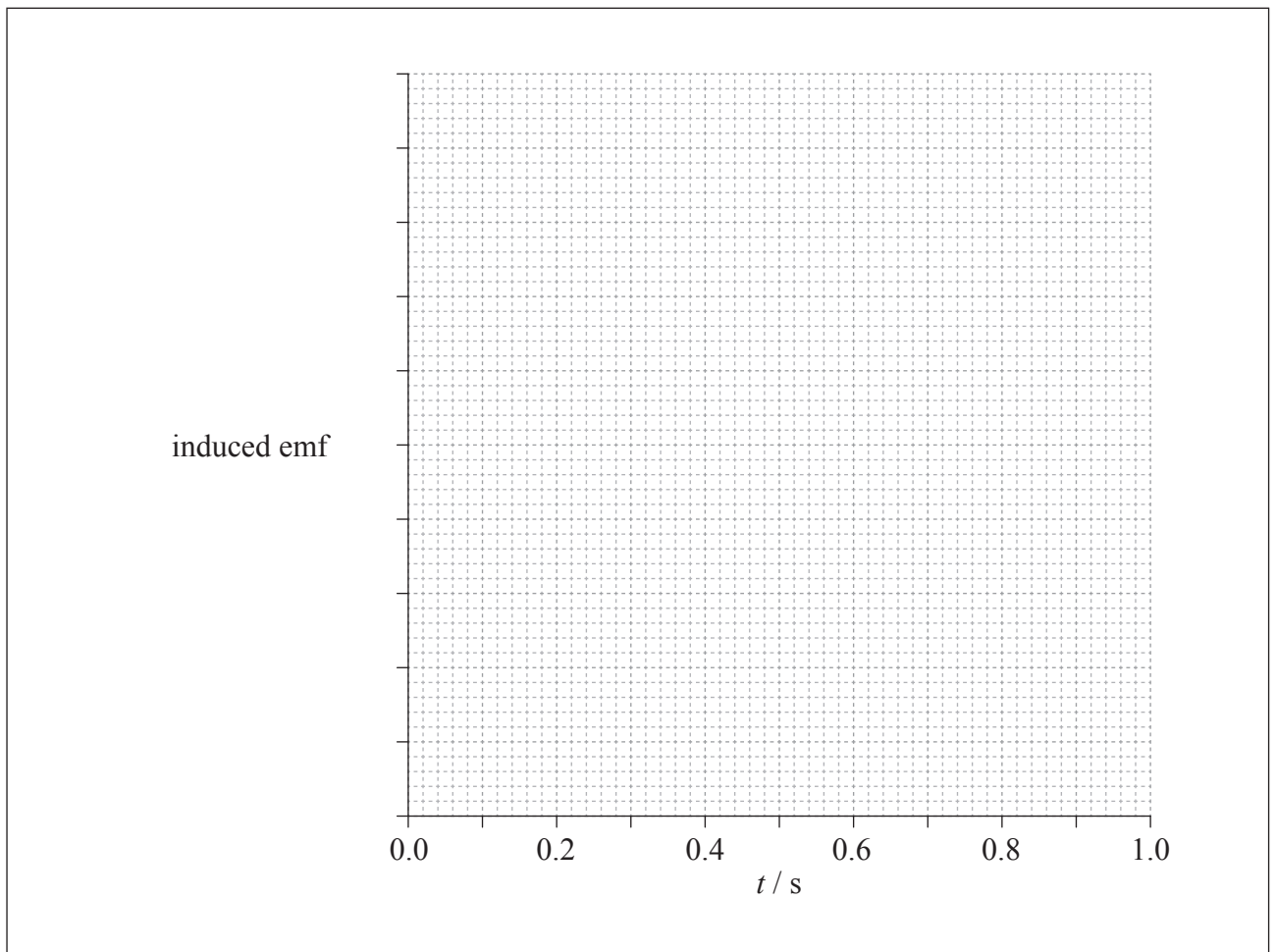

(This question continues on the following page)



*(Question 7 continued)*

(c) (i) Label the diagram of the magnet and coil on page 18 with arrows to show the direction of the conventional current as the north pole of the magnet approaches the coil. [1]

(ii) Explain your answer to (c)(i). [2]

.....

.....

.....

.....



Please **do not** write on this page.

Answers written on this page  
will not be marked.



24EP21

Turn over

8. (a) Outline what is meant by gravitational field strength. [2]

.....  
.....  
.....  
.....

- (b) X is a point on the line that joins the centre of the Earth and the centre of the Moon. At X, the resultant gravitational field strength of the Earth and the Moon is zero.

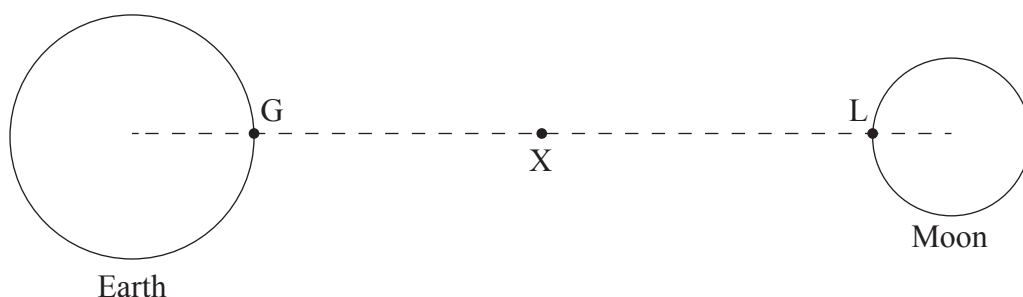

The following data are available.

|  |                                   |
|--|-----------------------------------|
| Mass of the Earth  | $= 6.0 \times 10^{24} \text{ kg}$ |
| Mass of the Moon   | $= 7.3 \times 10^{22} \text{ kg}$ |
| Radius of the Moon   | $= 1.7 \times 10^6 \text{ m}$     |
| Distance from the centre of the Earth to the surface of the Moon | $= 3.7 \times 10^8 \text{ m}$     |

- (i) Determine the ratio  $\frac{\text{distance of X from centre of the Earth}}{\text{distance of X from centre of the Moon}}$ . [2]

.....  
.....  
.....  
.....

*(This question continues on the following page)*



(Question 8 continued)

- (ii) Calculate, using the data, the total gravitational potential at the surface of the Moon due to the Earth and Moon. [3]

.....

.....

.....

.....

.....

.....

- (iii) G is a point on the surface of the Earth and L is a point on the surface of the Moon. Using the axes, sketch a graph to show how the total gravitational potential varies with distance from G to L. [3]

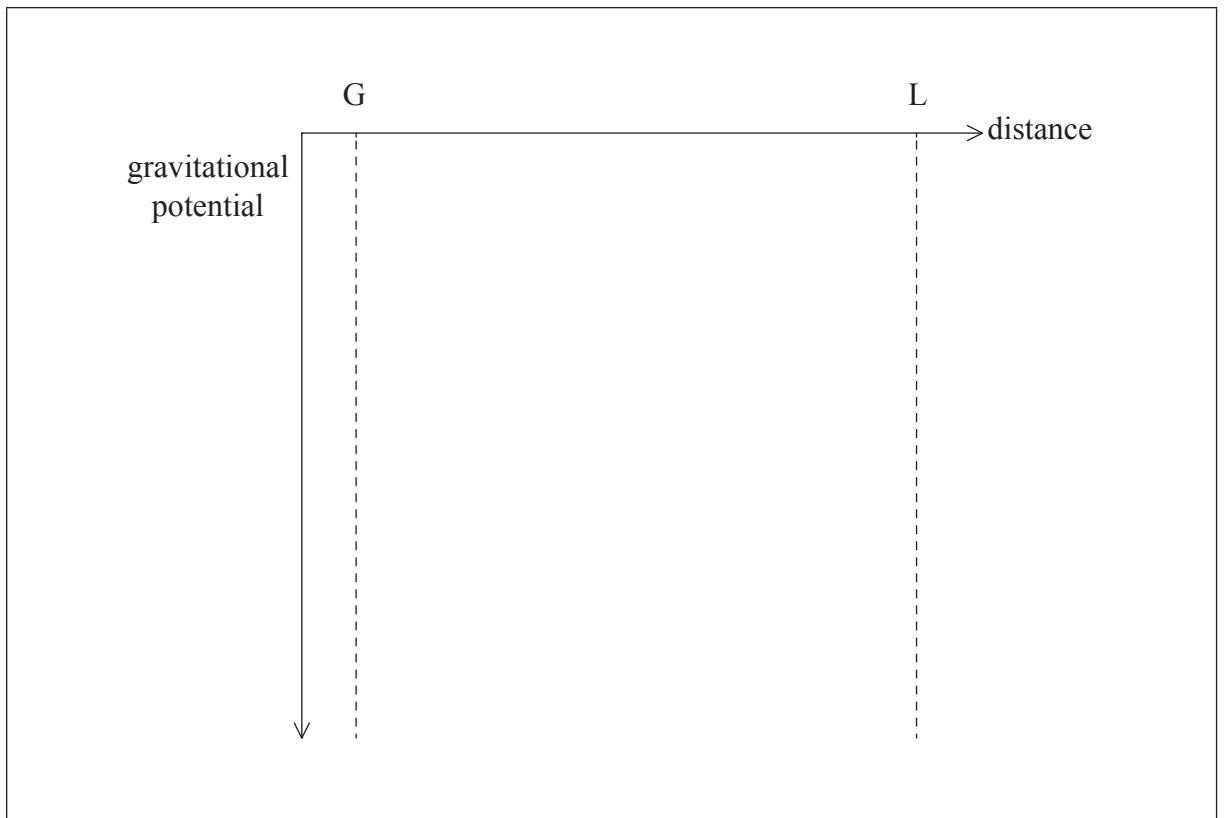

9. An electron and a positron can be created through pair production when a photon interacts with a nucleus.

(a) Explain why there is a photon frequency below which an electron–positron pair cannot be created. [2]

.....  
.....  
.....  
.....

(b) Calculate the minimum photon frequency for the production of an electron–positron pair. [3]

.....  
.....  
.....  
.....  
.....  
.....

(c) Outline why a nucleus must be involved in the interaction. [2]

.....  
.....  
.....  
.....





# **MARKSCHEME**

## **SPECIMEN PAPER**

### **PHYSICS**

#### **Higher Level**

#### **Paper 2**

## General Marking Instructions

### Subject Details: Physics HL Paper 2 Markscheme

#### Mark Allocation

Candidates are required to answer **ALL** questions. Maximum total = **[95 marks]**.

#### Markscheme format example:

| Question |   |    | Answers   | Notes                                 | Total |
|----------|---|----|---|---------------------------------------|-------|
| 4.       | b | ii | the displacement and acceleration ✓<br>are in opposite directions ✓ | <i>Accept force for acceleration.</i> | 2     |

- Each row in the “Question” column relates to the smallest subpart of the question.
- The maximum mark for each question subpart is indicated in the “Total” column.
- Each marking point in the “Answers” column is shown by means of a tick (✓) at the end of the marking point.
- A question subpart may have more marking points than the total allows. This will be indicated by “**max**” written after the mark in the “Total” column. The related rubric, if necessary, will be outlined in the “Notes” column.
- An alternative wording is indicated in the “Answers” column by a slash (/). Either wording can be accepted.
- An alternative answer is indicated in the “Answers” column by “**OR**” on the line between the alternatives. Either answer can be accepted.
- Words in angled brackets < > in the “Answers” column are not necessary to gain the mark.
- Words that are underlined are essential for the mark.
- The order of marking points does not have to be as in the “Answers” column, unless stated otherwise in the “Notes” column.
- If the candidate’s answer has the same “meaning” or can be clearly interpreted as being of equivalent significance, detail and validity as that in the “Answers” column then award the mark. Where this point is considered to be particularly relevant in a question it is emphasized by **OWTTE** (or words to that effect) in the “Notes” column.
- Remember that many candidates are writing in a second language. Effective communication is more important than grammatical accuracy.



12. Occasionally, a part of a question may require an answer that is required for subsequent marking points. If an error is made in the first marking point then it should be penalized. However, if the incorrect answer is used correctly in subsequent marking points then **follow through** marks should be awarded. When marking, indicate this by adding **ECF** (error carried forward) on the script. “ECF acceptable” will be displayed in the “Notes” column.
13. Do **not** penalize candidates for errors in units or significant figures, **unless** it is specifically referred to in the “Notes” column.

| Question |   | Answers  | Notes   | Total   |
|----------|---|--|---|---|
| 1.       | a | use of suitable kinematic equation eg: $-48 = 48 - 9.81t$ ✓<br>$9.8 \langle s \rangle$ ✓   | <i>Award [2] for a bald correct answer.</i>   | 2   |
|          | b | $0 = 48^2 - 2a8$ so $a = 144 \langle \text{ms}^{-2} \rangle$ ✓<br>$F_{\text{net}} = 480 \times 144 \langle = 6.9 \times 10^4 \rangle$ ✓<br>average force $\langle = 6.9 \times 10^4 + 0.47 \times 10^4 \rangle = 7.4 \times 10^4 \langle \text{N} \rangle$ ✓ |   | 3   |
|          | c | reaction force is zero ✓<br>because object and container fall at same rate ✓   |   | 2   |
|          | d | i  | volume = $120 \times \pi \times (3.5)^2 = 4620 \langle \text{m}^3 \rangle$ ✓<br>$n = \frac{0.96 \times \text{volume}}{(8.31 \times 300)} = 1.78$ ✓<br>number of molecules = $6.02 \times 10^{23} \times n = 1.1 \times 10^{24}$ ✓ | 3   |
|          | d | ii   | $\langle \text{yes} \rangle$<br>because pressure is low ✓<br>and temperature is high/moderate ✓   | 2   |
|          | e | i  | stopping distance $\langle \text{in polystyrene} \rangle / 8 \text{ m}$ ✓   | <i>Do not accept distance unqualified.</i><br>1         |
|          | e | ii   | gradient decreases as time increases before hitting the polystyrene ✓<br>lower maximum ✓<br>graph must go on longer before deceleration ✓<br>same total area by eye ✓   | <i>Accept a graph reaching terminal speed.</i><br>3 max |

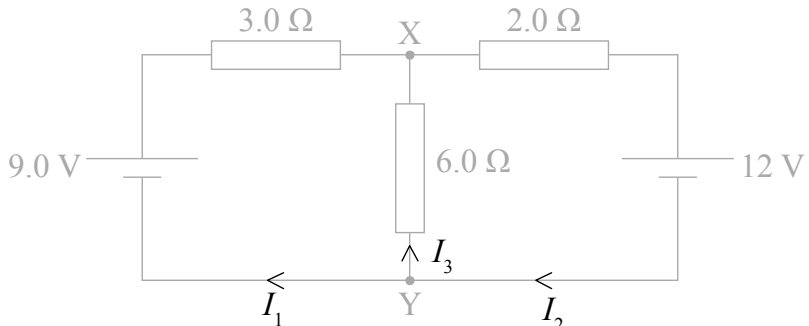
| Question |    | Answers  | Notes   | Total |
|----------|----|--|---|-------|
| 2.       | a  | <p>Kirchhoff 1 applied correctly ✓</p> <p>Kirchhoff 2 applied to one loop correctly ✓</p> <p>Kirchhoff 2 applied to a second loop correctly ✓</p> <p>simultaneous equations constructed correctly to give answer ✓</p> <p>direction of current stated towards X ✓</p>  <p>eg:</p> $I_2 = I_1 + I_3$ $9 = 3I_1 - 6I_3$ $12 = -2I_2 - 6I_3$ $9 = 3I_2 - 3I_3 - 6I_3$ $36 = -6I_2 - 18I_3$ $18 = 6I_2 - 18I_3$ $54 = -36I_3$ $I_3 = -1.5 \text{ A}$ | <p>Allow ECF from incorrect sign in the last marking point.</p> <p>Negative sign means current flow is from X to Y.</p> | 4 max |
| b        | i  | potential difference = $\langle 1.5 \times 6.0 \Rightarrow 9.0 \text{ V} \rangle$ ✓  |   | 1     |
| b        | ii | $\langle X \text{ is higher} \rangle$ because $\langle \text{conventional} \rangle$ current is flowing / positive charge would flow from X to Y ✓  |   | 1     |

| Question |   |     | Answers  | Notes                   | Total |
|----------|---|-----|--|-------------------------|-------|
| 3.       | a |     | correct curvature starting at 0,0 ✓<br>asymptotic to 6.0 <V> ✓   |                         | 2     |
|          | b | i   | use of $V = V_0 e^{-\frac{t}{RC}}$ ✓<br>$V = 6.0 e^{-\frac{6.3 \times 10^{-3}}{3300 \times 4.7 \times 10^{-6}}}$ ✓<br>4.00 <V> ✓   |                         | 3     |
|          | b | ii  | $Q_{\text{initial}} = \langle 6.0 \times 4.7 \times 10^{-6} \Rightarrow 28.2 \langle \mu\text{C} \rangle$<br><b>OR</b><br>$Q_{\text{final}} = \langle 4.00 \times 4.7 \times 10^{-6} \Rightarrow 18.8 \langle \mu\text{C} \rangle$ ✓<br>$\Delta Q = 9.4 \langle \mu\text{C} \rangle$ ✓ | Allow ECF from (b)(i).  | 2     |
|          | b | iii | battery capacity = $0.55 \times 3600 = 1980 \text{ C}$ ✓<br>$\langle \frac{1980}{9.4 \times 10^{-6} \times 3600 \times 24 \times 365} \Rightarrow 6.7 \text{ year} \rangle$ ✓  | Allow ECF from (b)(ii). | 2     |
|          | b | iv  | V values <all> double ✓<br>energy proportional to $V^2$ so $\times 4$ ✓  |                         | 2     |

| Question |   |    | Answers  | Notes  | Total |
|----------|---|----|--|--|-------|
| 4.       | a |    | travelling sound wave <is reflected at the barrier and> travels in opposite direction to original wave ✓<br>mention of interference/superposition ✓<br>minima caused by destructive interference ✓<br>maxima caused by constructive interference ✓<br><b>OR</b><br>travelling sound wave <reflects at the barrier and> travels in opposite direction to original wave ✓<br>reflected wave superposes with original wave ✓<br>forming a standing wave ✓<br>maxima are positions of antinodes, minima are positions of nodes ✓ |  | 4     |
|          | b | i  | recognition that 3.5 wavelengths are covered ✓<br>0.29 <m> ✓   |  | 2     |
|          | b | ii | measure each position of several minima/maxima using a ruler ✓<br>use data to determine mean wavelength ✓<br>measure frequency of waves using eg: oscilloscope/frequency meter/electronic guitar tuner ✓<br>use of $c = f\lambda$ ✓  | <i>Accept look up wave frequency or read from apparatus.</i> | 3 max |

| Question |   |     | Answers  | Notes  | Total |
|----------|---|-----|--|--|-------|
| 5.       | a | i   | power = $\langle \frac{7.5 \times 10^8 \times 100}{38} \Rightarrow 1.97 \times 10^9 \text{ J s}^{-1} \rangle \checkmark$   |  | 1     |
|          | a | ii  | $\frac{1.97 \times 10^9}{35} \checkmark$<br>56 $\checkmark$<br>MJ kg <sup>-1</sup> $\checkmark$  |  | 3     |
|          | b |     | plentiful supplies at present $\checkmark$<br>pre-existing infrastructure $\checkmark$   | <i>Accept easily portable, easily mined.</i> | 2     |
|          | c | i   | increased proportion of greenhouse gases in atmosphere $\checkmark$<br>so more absorption of infrared by atmosphere $\checkmark$<br>and extra energy radiated back to ground $\checkmark$  | <i>Accept any named greenhouse gas.</i>      | 3     |
|          | c | ii  | improved modelling<br><b>OR</b><br>greater data collection<br><b>OR</b><br>greater international collaboration $\checkmark$  |  | 1 max |
|          | d | i   | $\langle 235 + 1 - 148 - 85 \Rightarrow 3 \rangle \checkmark$  |  | 1     |
|          | d | ii  | mass difference = $\langle 148.932 + 84.910 + (2 \times 1.009) - 235.044 \rangle \checkmark$<br>$= 0.816 \text{ u} \checkmark$<br>760 MeV $\checkmark$   | <i>Allow ECF from (d)(i).</i>                | 3     |
|          | d | iii | neutrons emitted from uranium at high speed $\checkmark$<br>high speed neutrons do not cause fission $\checkmark$<br>neutrons collide with moderator atoms $\checkmark$<br>and therefore lose energy/speed before re-entering fuel rods $\checkmark$ |  | 3 max |

| Question |   |    | Answers  | Notes | Total |
|----------|---|----|--|-------|-------|
| 6.       | a |    | force of gravity is proportional to the product of <point> masses ✓<br>and inversely proportional to distance between centres squared ✓  |       | 2     |
|          | b | i  | force = $\langle \frac{Gm_1m_2}{r^2} \Rightarrow \frac{6.67 \times 10^{-11} \times 47 \times 0.73}{(1.25 \times 10^{-1})^2} \rangle$ ✓<br>0.15 <μN> ✓  |       | 2     |
|          | b | ii | doubling radius increases mass of spheres by × 8 ✓<br>so mass product increased by × 64 ✓<br>doubling radius increases separation by factor of 2 hence $r^2$ by 4 ✓<br>overall effect is increase in force by × 16 ✓ |       | 4     |
|          | c |    | same time period for any amplitude of swing ✓  |       | 1     |

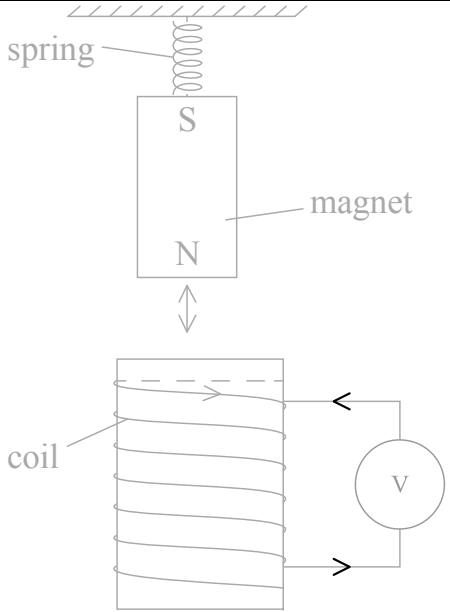
| Question |   | Answers   | Notes  | Total |
|----------|---|---|--|-------|
| 7.       | a | gradient calculation attempted at $t=0$ <i>or</i> 0.5 <i>or</i> 1.0 ✓<br>evidence of including number of turns and area ✓<br>3.2 <mV> ✓<br>answer expressed to two significant figures only ✓ | <i>Allow 3.0 mV to 3.4 mV.</i>                                       | 4     |
|          | b | cosine or negative cosine wave ✓<br>peak value double answer to part a ✓<br>period = 0.5 <s> ✓  |  | 3     |
|          | c | i<br> arrows as shown in diagram ✓  |  | 1     |
|          | c | ii<br>identifies north pole at top of coil ✓<br>uses stated direction rule to link induced north pole to current direction ✓  | <i>Allow answer in terms of Lenz's law or energy considerations.</i> | 2     |

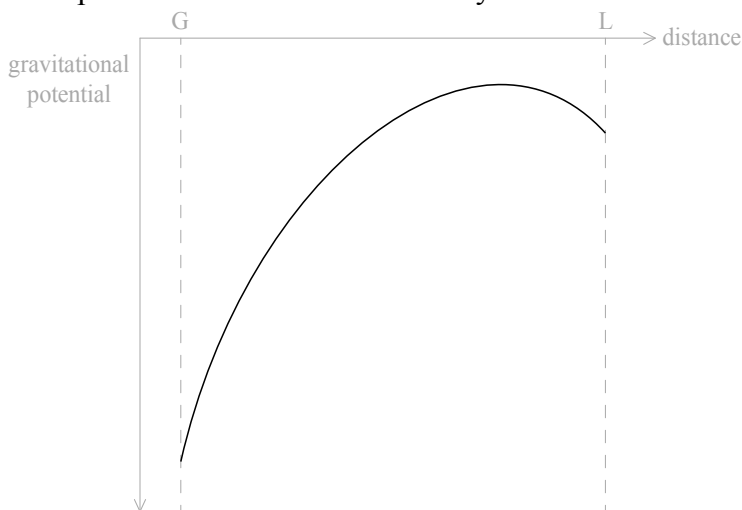

| Question |   |     | Answers   | Notes | Total |
|----------|---|-----|---|-------|-------|
| 8.       | a |     | force acting on ✓<br>unit mass ✓  |       | 2     |
|          | b | i   | $\frac{GM_e}{x^2} = \frac{GM_m}{y^2}$ ✓<br>$\frac{x}{y} = \sqrt{\frac{M_e}{M_m}} = \sqrt{81} = 9$ ✓   |       | 2     |
|          | b | ii  | for the Moon $V = \left\langle \frac{-GM}{r} \right\rangle = -2.9 \langle \text{MJ kg}^{-1} \rangle$ ✓<br>for the Earth $\langle - \rangle 1.1 \langle \text{MJ kg}^{-1} \rangle$ ✓<br>total gravitational potential = $-4.0 \langle \text{MJ kg}^{-1} \rangle$ ✓ |       | 3     |
|          | b | iii | graph rises close to but below zero ✓<br>falls to Moon ✓<br>from point much closer $\langle 10\% \text{ of way} \rangle$ to Moon than Earth ✓<br>                              |       | 3     |

| Question |   | Answers  | Notes               | Total |
|----------|---|--|---------------------|-------|
| 9.       | a | <p>there is a minimum energy required equal to the total mass of particles created<br/><i>OR</i><br/>reference to <math>\Delta E = \Delta m c^2</math> <b>and</b> <math>\Delta m = 2m_e</math> ✓<br/>energy of photon = <math>hf</math> &lt;so there is also a minimum frequency&gt; ✓</p> | <i>Both needed.</i> | 2     |
|          | b | <p>minimum energy = 1.02 &lt;MeV&gt; ✓<br/>= <math>1.63 \times 10^{-13}</math> &lt;J&gt; ✓<br/><math>2.5 \times 10^{20}</math> &lt;Hz&gt; ✓</p>  |                     | 3     |
|          | c | <p>&lt;both energy and&gt; momentum must be conserved in the interaction ✓<br/>nucleus absorbs the momentum &lt;to allow the interaction to occur&gt; ✓</p>  |                     | 2     |

---



**PHYSICS**  
**HIGHER LEVEL**  
**PAPER 3**

Candidate session number

|  |  |  |  |  |  |  |  |  |  |
|--|--|--|--|--|--|--|--|--|--|
|  |  |  |  |  |  |  |  |  |  |
|--|--|--|--|--|--|--|--|--|--|

SPECIMEN PAPER

Examination code

1 hour 15 minutes

|  |  |  |  |  |  |  |  |
|--|--|--|--|--|--|--|--|
|  |  |  |  |  |  |  |  |
|--|--|--|--|--|--|--|--|

## INSTRUCTIONS TO CANDIDATES

- Write your session number in the boxes above.
- Do not open this examination paper until instructed to do so.
- Section A: answer all questions.
- Section B: answer all of the questions from one of the options.
- Write your answers in the boxes provided.
- A calculator is required for this paper.
- A clean copy of the **Physics Data Booklet** is required for this paper.
- The maximum mark for this examination paper is [45 marks].

| Option                         | Questions |
|--------------------------------|-----------|
| Option A — Relativity          | 4 – 7     |
| Option B — Engineering physics | 8 – 11    |
| Option C — Imaging             | 12 – 14   |
| Option D — Astrophysics        | 15 – 18   |



SECTION A

Answer **all** questions. Write your answers in the boxes provided.

1. The speed of sound in air,  $v$ , was measured at temperatures near  $0^\circ\text{C}$ . The graph shows the data and the line of best-fit. The error bars for temperature are too small to be shown.

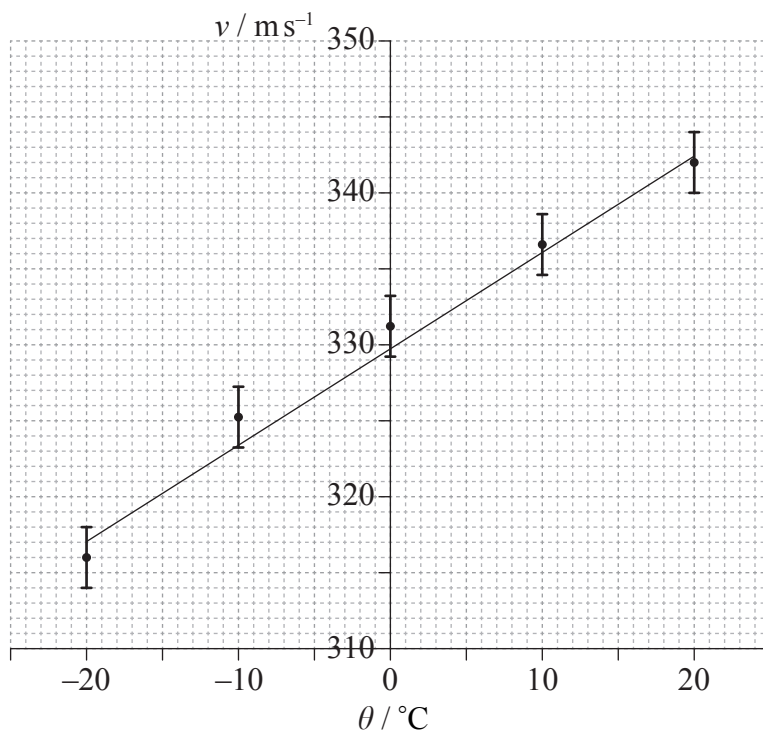

A student suggests that the speed of sound  $v$  is related to the temperature  $\theta$  in degrees Celsius by the equation

$$v = a + b\theta$$

where  $a$  and  $b$  are constants.

- (a) (i) Determine the value of the constant  $a$ , correct to two significant figures. [1]

.....

(This question continues on the following page)



(Question 1 continued)

- (ii) Estimate the absolute uncertainty in  $b$ . [3]

.....  
.....  
.....  
.....

- (iii) A student calculates that  $b = 0.593 \text{ ms}^{-1} \text{ }^\circ\text{C}^{-1}$ . State, using your answer to (a)(ii), the value of  $b$  to the correct number of significant figures. [1]

.....

- (b) (i) Estimate the temperature at which the speed of sound is zero. [1]

.....  
.....

- (ii) Explain, with reference to your answer in (b)(i), why the student's suggestion is not valid. [2]

.....  
.....  
.....  
.....



2. A student uses an electronic timer in an attempt to estimate the acceleration of free-fall  $g$ . She measures the time  $t$  taken for a small metal ball to fall through a height  $h$  of 0.50 m. The percentage uncertainty in the measurement of time is 0.3% and the percentage uncertainty height is 0.6%.

(a) Using  $h = \frac{1}{2}gt^2$ , calculate the expected percentage uncertainty in the value of  $g$ . [1]

.....  
.....  
.....  
.....

(b) State and explain how the student could obtain a more reliable value for  $g$ . [3]

.....  
.....  
.....  
.....  
.....  
.....



3. In an experiment to measure the specific heat capacity of a metal, a piece of metal is placed inside a container of boiling water at 100°C. The metal is then transferred into a calorimeter containing water at a temperature of 10°C. The final equilibrium temperature of the water was measured. One source of error in this experiment is that a small mass of boiling water will be transferred to the calorimeter along with the metal.

(a) Suggest the effect of the error on the measured value of the specific heat capacity of the metal. [2]

.....  
.....  
.....  
.....

(b) State **one** other source of error for this experiment. [1]

.....  
.....



**SECTION B**

Answer *all* of the questions from *one* of the options. Write your answers in the boxes provided.

**Option A — Relativity**

4. (a) Einstein discovered a discrepancy, related to the speed of light, between Maxwell's equations of electromagnetism and Newtonian mechanics. Outline the discrepancy and how Einstein dealt with it. [2]

.....

.....

.....

.....

.....

*(Option A continues on the following page)*





(Option A, question 4 continued)

- (b) A proton enters a region of uniform magnetic field which is directed into the plane of the page as shown.



Reference frame  $S$  is at rest with respect to the magnetic field. The speed of the proton is measured to be  $v$  in  $S$ .

- (i) State the nature of the force on the proton according to an observer in  $S$ . [1]

.....

- (ii)  $S'$  is a reference frame in which the proton is at rest. State and explain whether, according to an observer in  $S'$ , there is a force on the proton. [2]

.....  
.....  
.....  
.....

(Option A continues on the following page)



(Option A continued)

5. A rocket of proper length 900 m is moving at speed  $0.80c$  relative to the Earth. E is a reference frame in which the Earth is at rest. R is a reference frame in which the rocket is at rest. The diagram is from the point of view of E.

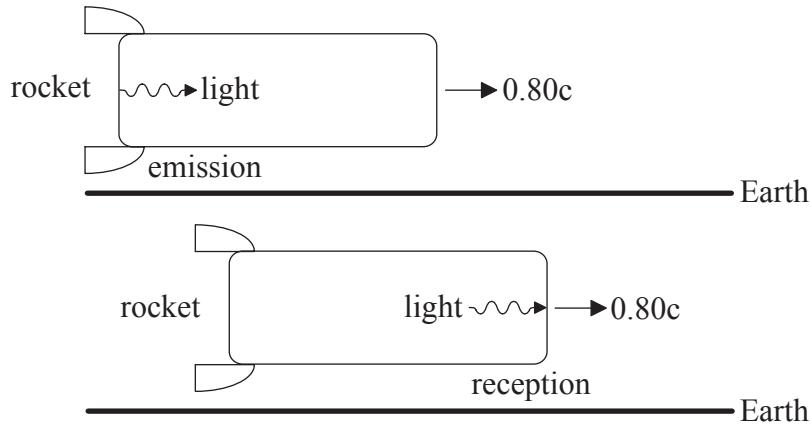

- (a) A light signal is emitted from the back of the rocket and is received at the front of the rocket.

Determine the

- (i) time interval between the emission and reception of the light signal according to an observer in R. [1]

.....

.....

- (ii) time interval between the emission and reception of the light signal according to an observer in E. [3]

.....

.....

.....

.....

(Option A continues on the following page)



*(Option A, question 5 continued)*

- (iii) distance separating the emission and reception of the light signal according to an observer in E. [1]

.....

.....

.....

.....

*(Option A continues on the following page)*



40EP09

**Turn over**

(Option A, question 5 continued)

- (b) One photon is emitted from the back B of the rocket and another photon is emitted from the front F of the rocket, as shown.

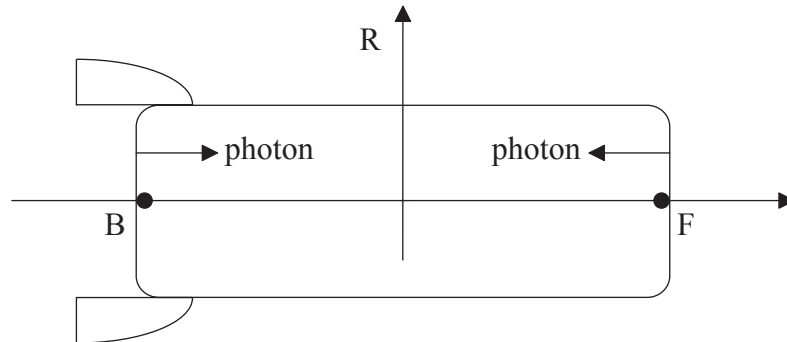

The emissions are simultaneous according to observers in R. The photons are received by an observer at rest in the middle of the rocket.

The spacetime diagram represents the reference frame of the Earth E and the rocket frame R. The coordinates in frame E are  $x$  and  $ct$  and in frame R they are  $x'$  and  $ct'$ . The position of the back B and of the front F of the rocket at  $t' = 0$  are labelled. The origin of the axes corresponds to the middle of the rocket.

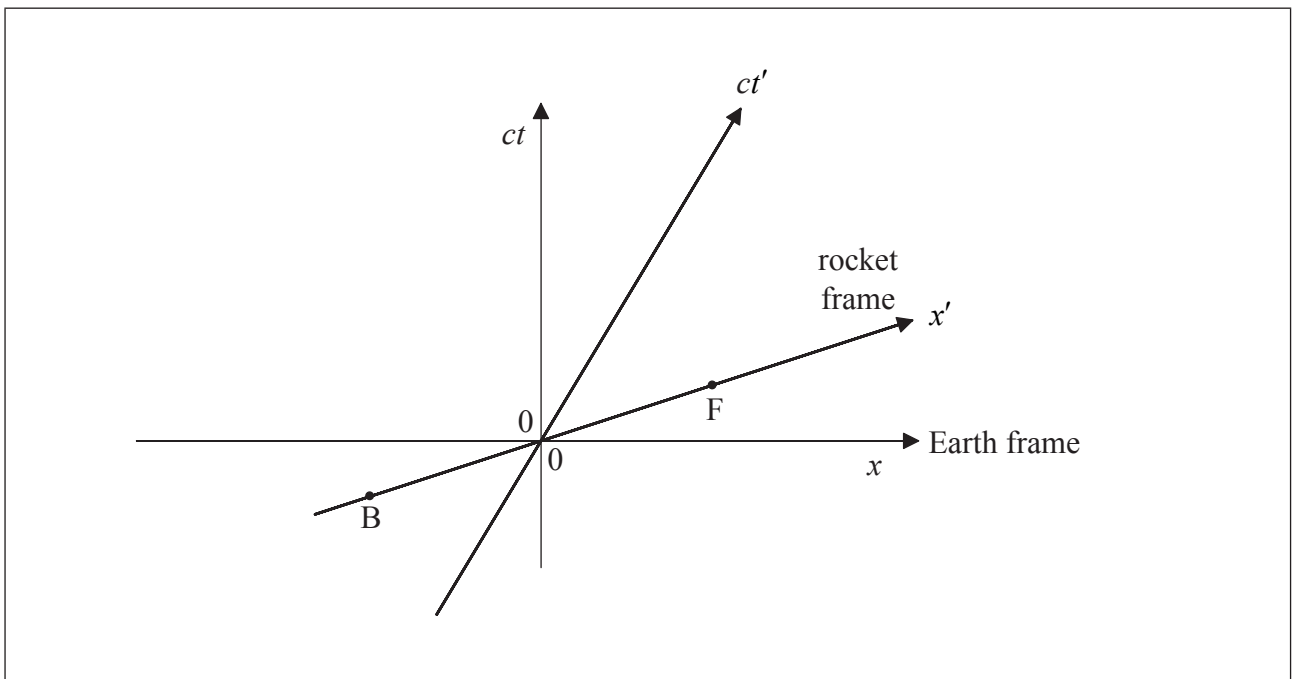

- (i) On the spacetime diagram, draw lines to show the worldlines of the photons from when they were emitted to when they were received. [3]

(Option A continues on the following page)

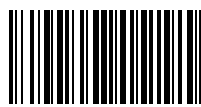

(Option A, question 5 continued)

- (ii) Using the spacetime diagram, determine which photon was emitted first according to observers in E. [2]

.....  
.....

- (iii) Determine the time separating the emissions of the two photons according to observers in E. [2]

.....  
.....  
.....  
.....

- (c) A missile is launched from the rocket. The velocity of the missile is  $-0.62c$  relative to the rocket. Calculate the velocity of the rocket relative to the Earth. [3]

.....  
.....  
.....  
.....

(Option A continues on the following page)



(Option A continued)

6. A neutral pion ( $\pi^0$ ) has total energy 1070 MeV as measured by observers in a laboratory. The pion decays in a vacuum into a pair of photons according to the following.

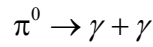

Photon X is emitted in the direction of the velocity of the pion and photon Y is emitted in the opposite direction. The rest mass of the pion is  $m = 135 \text{ MeV c}^{-2}$ .

- (a) Show that the momentum of the pion is  $1060 \text{ MeV c}^{-1}$ . [1]

|                |
|----------------|
| .....<br>..... |
|----------------|

- (b) The energy of photon X is  $E_X$  and the energy of photon Y is  $E_Y$ . Using the laws of conservation of total energy and momentum, calculate  $E_Y$ . [3]

|                                  |
|----------------------------------|
| .....<br>.....<br>.....<br>..... |
|----------------------------------|

*(Option A continues on the following page)*



*(Option A continued)*

7. (a) (i) State the equivalence principle.

[1]

.....  
.....  
.....

(ii) Explain, using the equivalence principle, the phenomenon of gravitational redshift. [3]

.....  
.....  
.....  
.....

*(Option A continues on the following page)*



(Option A, question 7 continued)

- (b) A clock is placed at a distance  $r$  from the centre of a black hole of radius  $R_s$  such that  $\frac{r}{R_s} = 1.25$ .

The clock ticks once every second according to stationary observers next to the clock. Calculate the time between ticks of this clock according to observers far from the black hole.

[2]

.....

.....

**End of Option A**





Please **do not** write on this page.

Answers written on this page  
will not be marked.



40EP15

Turn over

**Option B — Engineering physics**

8. A bucket of mass  $m$  is held above a water well by a rope of negligible mass, as shown. The rope is wound around a cylinder of mass  $M$  and radius  $R$ . The moment of inertia of the cylinder about its axis is  $I = \frac{1}{2}MR^2$ .

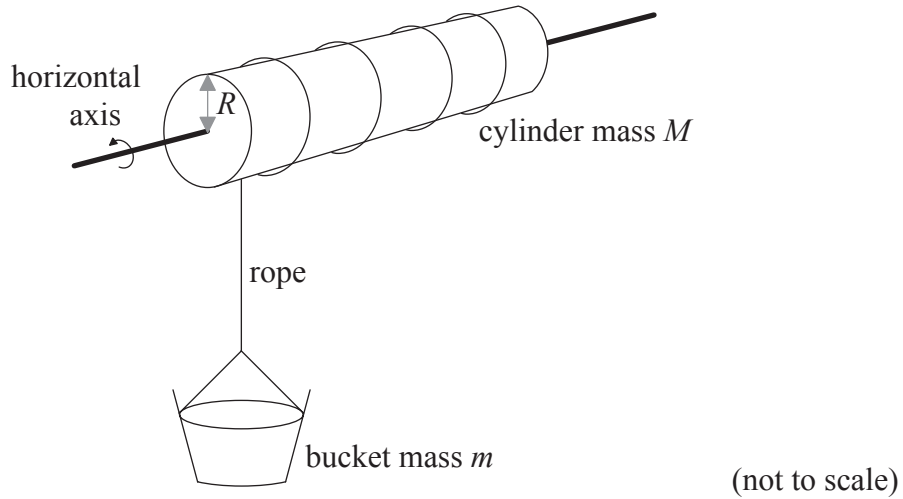

The bucket is released from rest. Resistance forces may be ignored.

- (a) Show that the acceleration  $a$  of the bucket is given by the following equation.

$$a = \frac{mg}{m + \frac{M}{2}} \quad [4]$$

.....

.....

.....

.....

.....

.....

*(Option B continues on the following page)*



(Option B, question 8 continued)

(b) The following data are available.

Bucket mass  $m = 24$  kg  
Cylinder mass  $M = 36$  kg  
Radius  $R = 0.20$  m

(i) Calculate the speed of the bucket when it has fallen a distance of 16 m from rest. [2]

.....  
.....  
.....  
.....

(ii) Calculate the rate of change of the angular momentum of the cylinder. [3]

.....  
.....  
.....  
.....

(c) The bucket in (b) is filled with water so its total mass is now 45 kg. The bucket is raised at a constant speed of  $2.0 \text{ m s}^{-1}$  using an electric motor attached to the cylinder. Calculate the power output of the motor. [1]

.....  
.....

(Option B continues on the following page)



(Option B continued)

9. The pressure volume ( $pV$ ) diagram shows a cycle ABCA of a heat engine. The working substance of the engine is a fixed mass of an ideal gas.

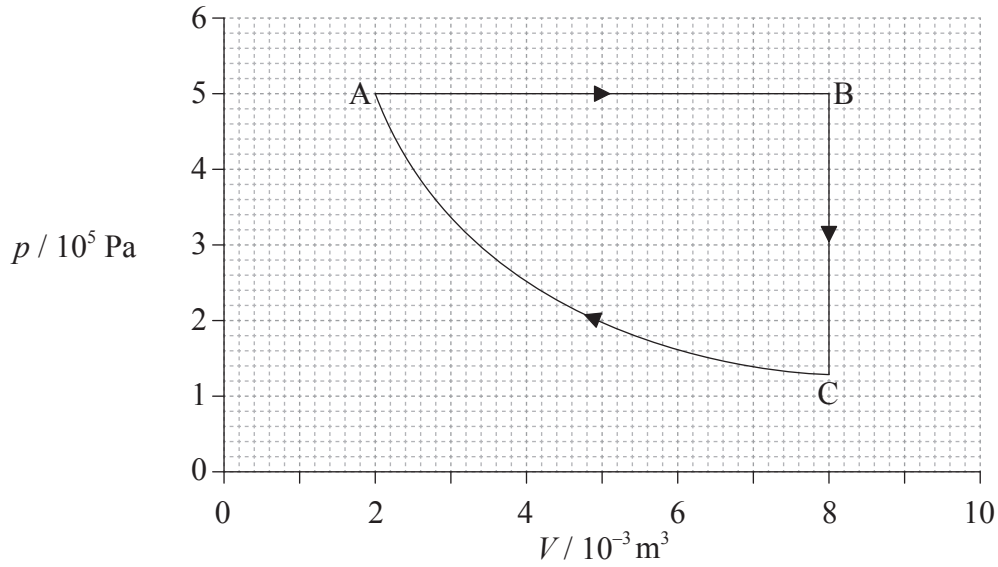

The temperature of the gas at A is 400 K.

- (a) Calculate the maximum temperature of the gas during the cycle.

[1]

.....

.....

(Option B continues on the following page)



*(Option B, question 9 continued)*

(b) For the isobaric expansion AB, calculate the

(i) work done by the gas. [2]

.....

.....

.....

.....

(ii) change in the internal energy of the gas. [1]

.....

.....

.....

.....

(iii) thermal energy transferred to the gas. [1]

.....

.....

.....

.....

*(Option B continues on the following page)*



(Option B, question 9 continued)

- (c) The work done on the gas during the isothermal compression is 1390J. Determine the change in entropy of the gas for this compression. [2]

.....

.....

.....

.....

- (d) Determine the efficiency of the cycle ABCA. [2]

.....

.....

.....

.....

- (e) State whether the efficiency of a Carnot engine operating between the same temperatures as those operating in cycle ABCA on page 18, would be greater than, equal to, or less than the efficiency in (d). [1]

.....

(Option B continues on page 22)



Please **do not** write on this page.

Answers written on this page  
will not be marked.



40EP21

Turn over

*(Option B continued from page 20)*

10. The diagram shows streamlines past an airfoil that is placed in a stream of air. The flow is laminar.

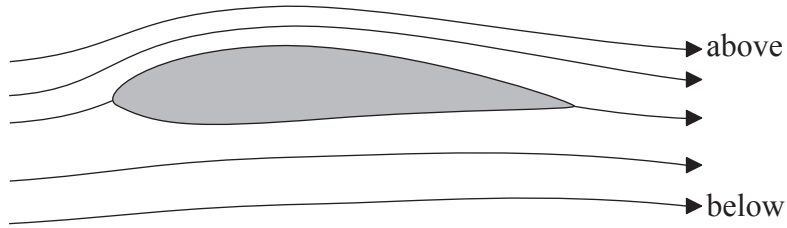

- (a) State what is meant by laminar flow.

[1]

.....  
.....

*(Option B continues on the following page)*

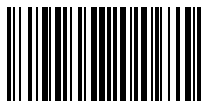



(Option B, question 10 continued)

- (b) (i) The streamlines above the airfoil are closer to each other than the streamlines below the airfoil. Suggest why this implies that the speed of the air above the airfoil is greater than the speed of air below the airfoil. [2]

.....  
.....  
.....  
.....

- (ii) The speed of air above the airfoil is  $64 \text{ m s}^{-1}$  and the speed of air below the airfoil is  $52 \text{ m s}^{-1}$ . The density of air is  $0.95 \text{ kg m}^{-3}$ . The areas of the upper and lower surfaces of the airfoil are both effectively  $2.0 \text{ m}^2$  and the airfoil is very thin. Determine the lift on the airfoil. [3]

.....  
.....  
.....  
.....

(Option B continues on the following page)



(Option B continued)

11. A spring performs damped harmonic oscillations. The graph shows the variation with time  $t$  of the displacement  $x$  of the spring.

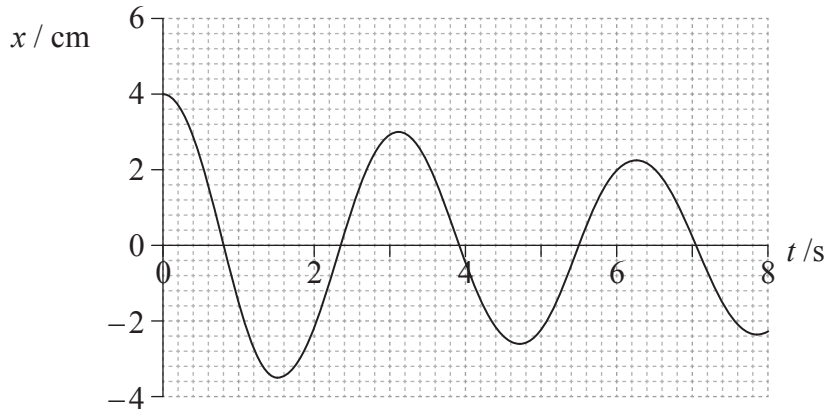

- (a) Estimate the  $Q$  factor of the spring.

[2]

.....  
.....  
.....  
.....

(Option B continues on the following page)



*(Option B, question 11 continued)*

- (b) The damped spring is now subjected to an external periodic driving force whose frequency is close to the natural frequency of the spring.

Suggest the effect, if any,

- (i) of this force on the steady-state amplitude of oscillations of the spring. *[1]*

.....

- (ii) on the phase difference between the driven and the driving systems. *[1]*

.....

**End of Option B**



**Option C — Imaging**

12. (a) The diagram shows a Cassegrain reflecting telescope consisting of a small diverging mirror  $M_1$ , a large converging mirror  $M_2$ , and a converging lens  $L$ . The focal point of  $M_2$  is at  $F$ .

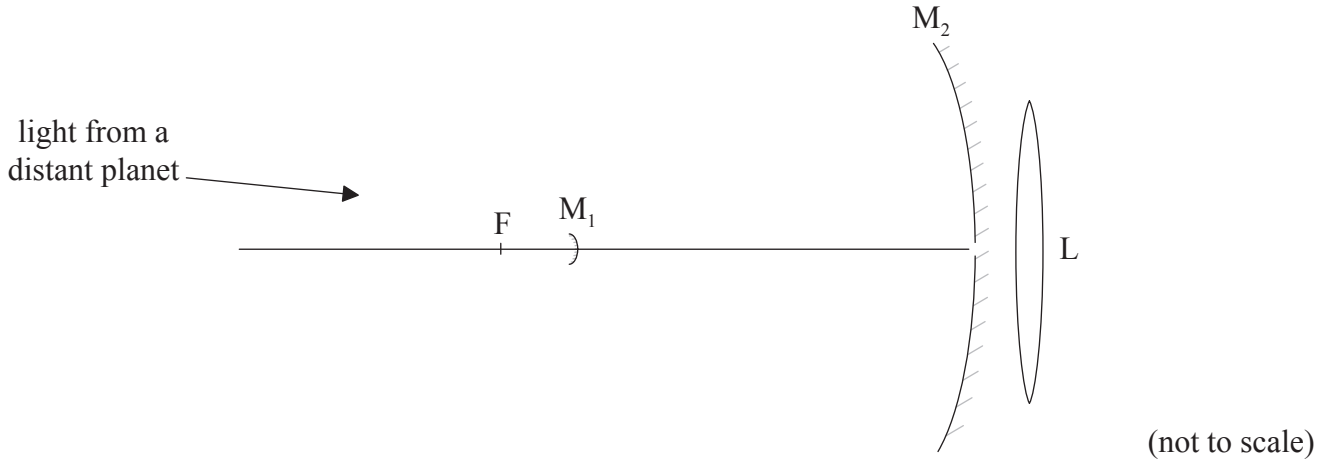

The telescope is used to view a planet. The diameter of the planet subtends an angle of  $1.40 \times 10^{-4}$  rad at  $M_2$ . The focal length of  $M_2$  is 9.50 m.

- (i) Show that the diameter of the image of the planet that would be formed by  $M_2$  alone is 1.33 mm. [3]

.....

.....

.....

.....

*(Option C continues on the following page)*

*(Option C, question 12 continued)*

- (ii)  $M_1$  is at a distance of 8.57 m from the aperture of  $M_2$ . The image in (a)(i) now serves as a virtual object for  $M_1$ . A real image is formed at the opening of  $M_2$ . Show that the diameter of this image is 12.0 mm. [3]

.....

.....

.....

.....

- (iii) The real image in (a)(ii) is now viewed by L of focal length 98.0 mm. The final image of the planet is formed at infinity. Calculate the overall magnification of the telescope. [3]

.....

.....

.....

.....

.....

.....

*(Option C continues on the following page)*



(Option C, question 12 continued)

- (b) (i) The large concave mirror in most reflecting telescopes is parabolic rather than spherical. Suggest **one** reason for this. [1]

.....  
.....

- (ii) State **one** advantage of reflecting telescopes compared to refracting telescopes. [1]

.....  
.....  
.....  
.....

- (c) Telescopes available today include, in addition to optical telescopes, infrared, radio, ultraviolet and X-ray telescopes. Outline how the introduction of these telescopes has changed our view of the universe. [2]

.....  
.....  
.....  
.....

(Option C continues on the following page)



(Option C continued)

13. (a) A compound microscope has an objective lens of focal length 0.40 cm and an eyepiece lens of focal length 3.20 cm. The image formed by the objective is 0.20 m from the objective lens. The final image is formed at a distance of 25 cm from the eyepiece lens.

(i) Show that the position of the object is  $4.1 \times 10^{-3}$  m from the objective lens. [1]

.....  
.....

(ii) Determine the angular magnification of the microscope. [2]

.....  
.....  
.....  
.....

(iii) The smallest distance between two points that can be distinguished by an unaided human eye from a distance of 25 cm is approximately 0.1 mm. Calculate the smallest distance between two points that can be distinguished using this microscope. [1]

.....  
.....

(Option C continues on the following page)



(Option C, question 13 continued)

- (b) The images from the microscope are digitized and transmitted along an optic fibre. The input power of the signal is 120 mW and the attenuation per unit length of the optic fibre is  $6.2 \text{ dB km}^{-1}$ . The length of the fibre is 4.6 km. Calculate the output power of the signal. [3]

.....

.....

.....

.....

.....

.....

- 14. (a) One of the factors affecting the quality of an X-ray image is sharpness.

- (i) Outline what is meant by sharpness. [1]

.....

.....

- (ii) State **one** way in which the sharpness of an X-ray image may be improved. [1]

.....

.....

(Option C continues on the following page)





(Option C, question 14 continued)

- (b) The graph shows how the linear absorption coefficient  $\mu$ , for tissue, varies with photon energy  $E$ .

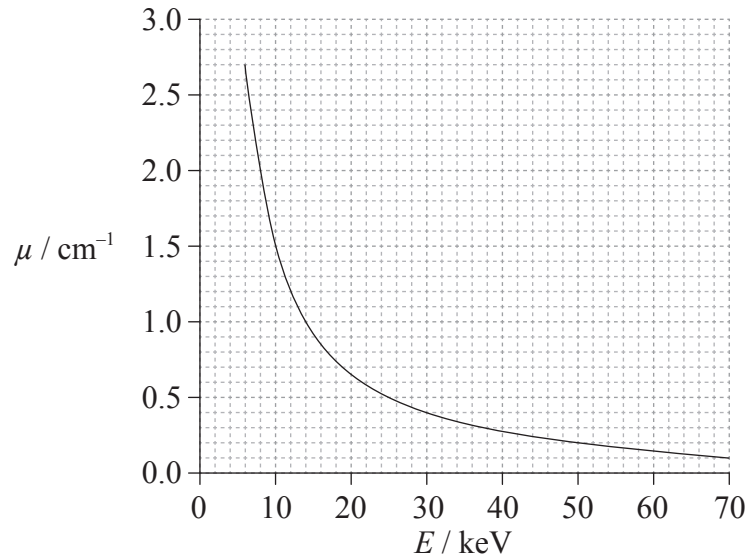

- (i) Suggest why it is desirable to remove the low-energy photons from the beam. [1]

.....  
.....

- (ii) Determine, for X-rays of energy 50 keV, the percentage of the incident intensity that is transmitted through a tissue section of thickness 2.0 cm. [2]

.....  
.....  
.....  
.....

(Option C continues on the following page)



(Option C, question 14 continued)

(c) Explain, in the context of magnetic resonance imaging (MRI), the role of the

(i) radio frequency (RF) signal.

[1]

.....  
.....  
.....

(ii) gradient field.

[1]

.....  
.....  
.....

(iii) proton spin relaxation time.

[1]

.....  
.....  
.....

(d) State **two** advantages of using MRI rather than X-rays for imaging the brain.

[2]

.....  
.....  
.....  
.....

**End of Option C**



**Option D — Astrophysics**

15. (a) State the element which is the end product of nuclear reactions taking place inside main sequence stars. [1]

.....

- (b) A main sequence star has apparent brightness  $7.6 \times 10^{-14} \text{ W m}^{-2}$  and luminosity  $3.8 \times 10^{27} \text{ W}$ .

- (i) Calculate, in pc, the distance of the star from Earth. [3]

.....  
.....  
.....  
.....

- (ii) Suggest whether the stellar parallax method is appropriate for measuring the distance to this star. [1]

.....  
.....

- (iii) The luminosity of the star in (b) is ten times the luminosity of our Sun.

Determine the ratio  $\frac{M}{M_{\odot}}$  where  $M_{\odot}$  is the mass of the Sun. [2]

.....  
.....  
.....  
.....

*(Option D continues on the following page)*



(Option D, question 15 continued)

(c) The image shows a Hertzsprung–Russell (HR) diagram.

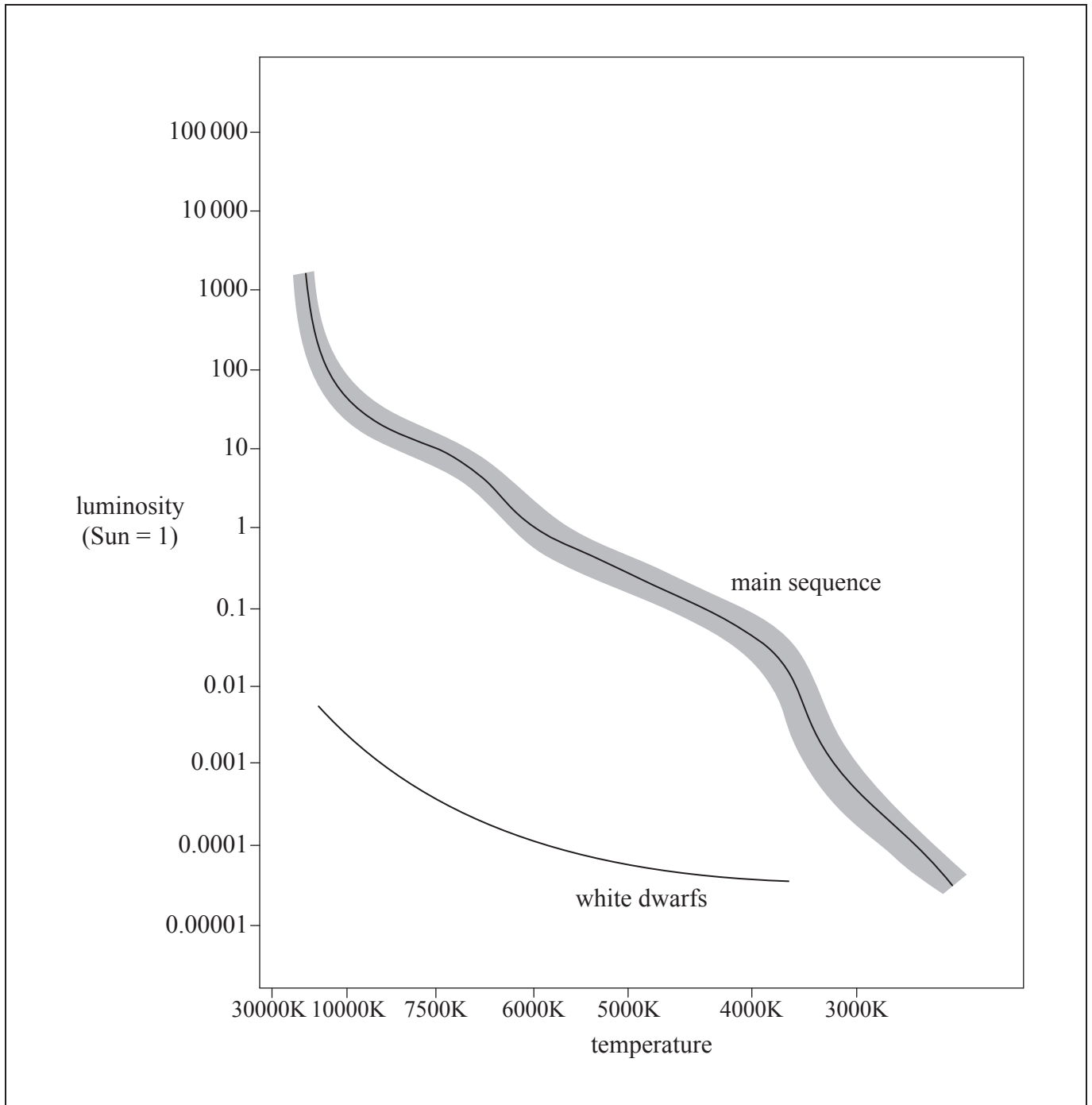

(Option D continues on the following page)



*(Option D, question 15 continued)*

- (i) Estimate, using the HR diagram, the ratio  $\frac{R}{R_{\odot}}$  where  $R$  is the radius of the star in (b) and  $R_{\odot}$  is the radius of the Sun. [3]

.....  
.....  
.....  
.....

- (ii) Sketch a line on the HR diagram to show the evolutionary path of this star. [2]

- (iii) Describe, with reference to the Chandrasekhar limit, the equilibrium state of this star in its final evolutionary stage. [2]

.....  
.....  
.....  
.....

*(Option D continues on the following page)*



*(Option D continued)*

16. (a) The hydrogen spectrum from a laboratory source includes a line of wavelength 434 nm. The same line emitted from a distant galaxy has wavelength 502 nm when observed on Earth.

(i) Suggest why the two wavelengths are different. [1]

.....

.....

(ii) Determine the distance, in Mpc, from this galaxy to Earth using a Hubble constant of  $71 \text{ km s}^{-1} \text{ Mpc}^{-1}$ . [2]

.....

.....

.....

.....

*(Option D continues on the following page)*



*(Option D, question 16 continued)*

(b) In the 1990s, two research groups started projects involving observations of distant supernovae. They aimed to show that distant galaxies were slowing down.

(i) Suggest why it was expected that distant galaxies would be slowing down. [1]

.....  
.....

(ii) Describe how it was deduced that the universe is expanding at an accelerated rate. [2]

.....  
.....  
.....  
.....

*(Option D continues on the following page)*



*(Option D continued)*

17. (a) Suggest why nuclear fusion processes inside stars can only produce elements with a nucleon (mass) number up to about sixty. [2]

.....  
.....  
.....  
.....  
.....

- (b) Outline how elements of nucleon (mass) number higher than sixty are produced by stars. [2]

.....  
.....  
.....  
.....  
.....

*(Option D continues on the following page)*





(Option D continued)

18. (a) Measurements by WMAP have revealed very small deviations from isotropy in the cosmic microwave background (CMB) radiation. Suggest why it was important that the CMB should not be perfectly isotropic. [2]

.....

.....

.....

.....

- (b) Another WMAP result is that the universe is flat. The graph shows how the scale factor of the universe  $R$ , varies with time  $t$  in a flat universe **without** dark energy.

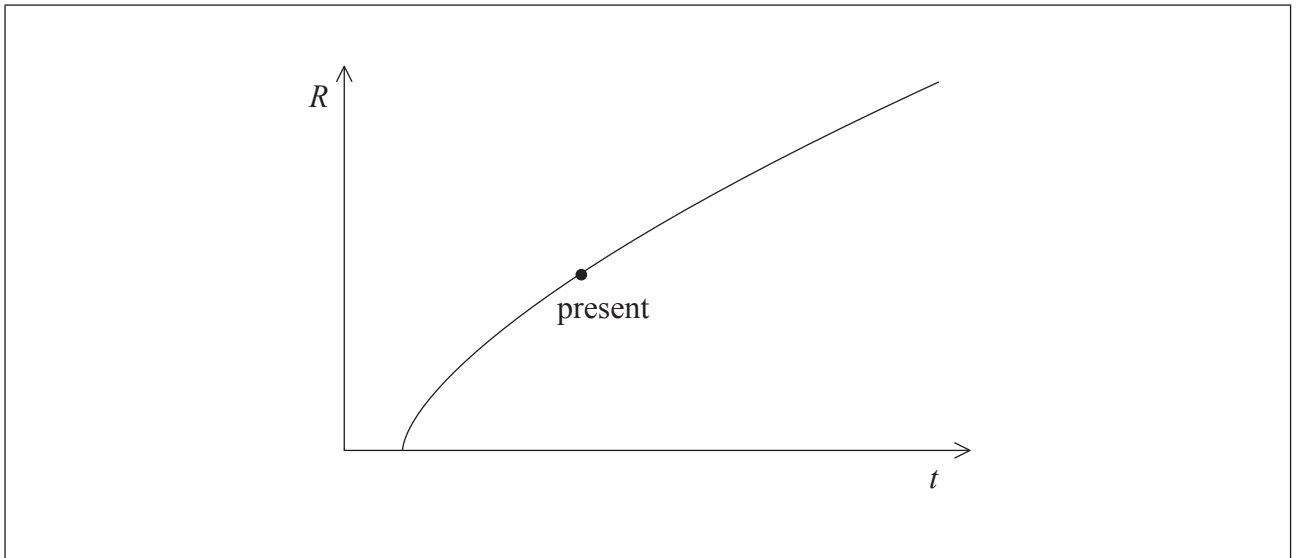

Using the axes, draw a curve to show how the scale factor varies with time in a flat universe **with** dark energy. [1]

(Option D continues on the following page)



(Option D, question 18 continued)

- (c) The graph shows the variation of the rotational speeds of stars  $v_{\text{circ}}$  with distance  $r$  from the center of a galaxy.

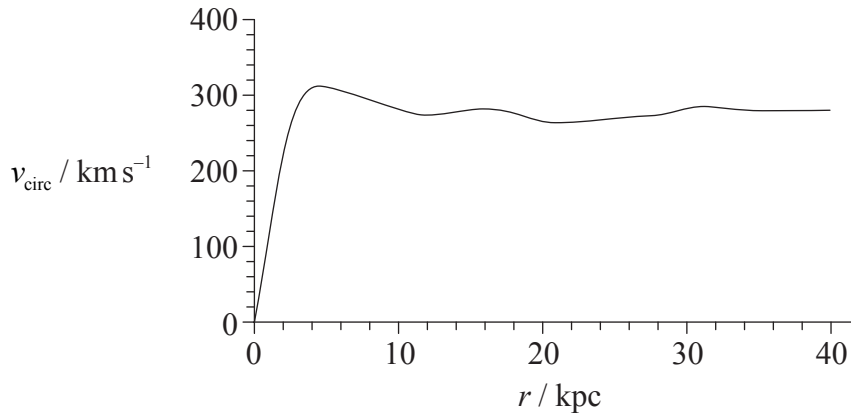

- (i) State the feature of the graph that indicates the existence of dark matter. [1]

.....

- (ii) Explain how the feature you stated in (c)(i) indicates the existence of dark matter. [2]

.....  
.....  
.....  
.....

**End of Option D**





# **MARKSCHEME**

## **SPECIMEN PAPER**

### **PHYSICS**

#### **Higher Level**

#### **Paper 3**

## General Marking Instructions

### Subject Details: Physics HL Paper 3 Markscheme

#### Mark Allocation

Candidates are required to answer **ALL** questions in Section A [**15 marks**] and all questions from **ONE** option in Section B [**30 marks**].  
Maximum total = [**45 marks**].

#### Markscheme format example:

| Question |   |    | Answers   | Notes                                 | Total |
|----------|---|----|---|---------------------------------------|-------|
| 4.       | b | ii | the displacement and acceleration ✓<br>are in opposite directions ✓ | <i>Accept force for acceleration.</i> | 2     |

- Each row in the “Question” column relates to the smallest subpart of the question.
- The maximum mark for each question subpart is indicated in the “Total” column.
- Each marking point in the “Answers” column is shown by means of a tick (✓) at the end of the marking point.
- A question subpart may have more marking points than the total allows. This will be indicated by “**max**” written after the mark in the “Total” column. The related rubric, if necessary, will be outlined in the “Notes” column.
- An alternative wording is indicated in the “Answers” column by a slash (/). Either wording can be accepted.
- An alternative answer is indicated in the “Answers” column by “**OR**” on the line between the alternatives. Either answer can be accepted.
- Words in angled brackets < > in the “Answers” column are not necessary to gain the mark.
- Words that are underlined are essential for the mark.
- The order of marking points does not have to be as in the “Answers” column, unless stated otherwise in the “Notes” column.
- If the candidate’s answer has the same “meaning” or can be clearly interpreted as being of equivalent significance, detail and validity as that in the “Answers” column then award the mark. Where this point is considered to be particularly relevant in a question it is emphasized by **OWTTE** (or words to that effect) in the “Notes” column.
- Remember that many candidates are writing in a second language. Effective communication is more important than grammatical accuracy.

12. Occasionally, a part of a question may require an answer that is required for subsequent marking points. If an error is made in the first marking point then it should be penalized. However, if the incorrect answer is used correctly in subsequent marking points then **follow through** marks should be awarded. When marking, indicate this by adding **ECF** (error carried forward) on the script. “ECF acceptable” will be displayed in the “Notes” column.
13. Do **not** penalize candidates for errors in units or significant figures, **unless** it is specifically referred to in the “Notes” column.

SECTION A

| Question |   |     | Answers   | Notes  | Total |
|----------|---|-----|---|--|-------|
| 1.       | a | i   | $a = 330 \text{ } \langle \text{ms}^{-1} \rangle \checkmark$  |  | 1     |
|          | a | ii  | $b_{\text{max}} = \langle \frac{344 - 316}{40} \rangle = \langle 0.70 \text{ } \langle \text{ms}^{-1} \text{ } ^\circ\text{C}^{-1} \rangle \checkmark$<br>$b_{\text{min}} = \langle \frac{340 - 318}{40} \rangle = \langle 0.55 \text{ } \langle \text{ms}^{-1} \text{ } ^\circ\text{C}^{-1} \rangle \checkmark$<br>$\Delta b = \langle \frac{0.70 - 0.55}{2} \rangle = \langle 0.075 \approx \rangle \langle 0.08 \text{ } \langle \text{ms}^{-1} \text{ } ^\circ\text{C}^{-1} \rangle \checkmark$ |  | 3     |
|          | a | iii | $b = 0.59 (\pm 0.08) \text{ } \langle \text{ms}^{-1} \text{ } ^\circ\text{C}^{-1} \rangle \checkmark$   | <i>Allow 0.593 (<math>\pm 0.075</math>).</i> | 1     |
|          | b | i   | $\theta = \langle \frac{-330}{0.6} \rangle = \langle -550 \text{ } \langle ^\circ\text{C} \rangle \checkmark$   |  | 1     |
|          | b | ii  | temperature is unphysical<br><b>OR</b><br>there is no temperature below $-273^\circ\text{C}$<br><b>OR</b><br>this temperature cannot be right $\checkmark$<br>it appears that the linear fit model cannot be extrapolated far from $0^\circ\text{C}$ $\checkmark$   |  | 2     |

| Question |   | Answers   | Notes   | Total |
|----------|---|---|---|-------|
| 2.       | a | the estimated percentage uncertainty in $g$ $\langle$ is $2 \times 0.3 + 0.6 \rangle = 1\%$ ✓   | <i>Accept 1.2%.</i>   | 1     |
|          | b | use more than one height ✓<br>obtain $g$ from a suitable graph $\langle$ of height $h$ versus $t^2 \rangle$ ✓<br>$g$ is twice the gradient ✓<br><b>OR</b><br>use a smaller ball $\langle$ to reduce air resistance $\rangle$ ✓<br>use a $\langle$ much $\rangle$ larger height ✓<br>repeat many times $\langle$ to get an average of time $\rangle$ ✓ | <i>Allow <math>h</math> versus <math>t^2</math> or <math>\sqrt{h}</math> versus <math>t</math> or <math>\log h</math> <math>\log t</math> .</i><br><i>Analysis of <math>g</math> must fit quoted graph.</i> | 3     |
| 3.       | a | the actual specific heat capacity will be less than calculated value ✓<br>more thermal energy is transferred to the calorimeter and contents than accounted for ✓   | <i>Do not allow a bald answer.</i>  | 2     |
|          | b | metal may not have been heated uniformly<br><b>OR</b><br>metal may not all be at $100^\circ\text{C}$ ✓<br>energy was lost to air during the transfer ✓<br>energy may have been lost to the air through the calorimeter ✓<br>water may not be at uniform temperature ✓   |   | 1 max |

SECTION B

Option A — Relativity

| Question |   |    | Answers   | Notes  | Total |
|----------|---|----|---|--|-------|
| 4.       | a |    | Maxwell's equations implied a speed of light independent of its source<br><b>OR</b><br>in Newtonian mechanics, speed of light depends on velocity of source ✓<br><br>Einstein trusted Maxwell's equations<br><b>OR</b><br>Einstein modified Newtonian mechanics ✓ |  | 2     |
|          | b | i  | magnetic ✓  |  | 1     |
|          | b | ii | if a force exists in one ⟨inertial⟩ frame a force must exist in any other ⟨inertial⟩ frame ✓<br><br>cannot be magnetic because the proton is at rest in $S'$ ✓  | <i>Accept discussion in terms of acceleration as equivalent to force.<br/>Accept an answer in terms of electric field.</i> | 2     |

|    |   |    |  |  |   |
|----|---|----|--|--|---|
| 5. | a | i  | $\langle \frac{900}{c} \Rightarrow 3.0 \times 10^{-6} \langle s \rangle \checkmark$  |  | 1 |
|    | a | ii | $\gamma = \langle \frac{1}{\sqrt{1 - \frac{v^2}{c^2}}} = \frac{1}{\sqrt{1 - 0.64}} \Rightarrow \frac{5}{3} \approx 1.67 \checkmark$<br><br>$\Delta t = \langle \gamma \left[ \Delta t' + \frac{v \Delta x'}{c^2} \right] \Rightarrow \frac{5}{3} \left[ 3.0 \times 10^{-6} + \frac{0.80c \times 900}{c^2} \right] \checkmark$<br><br>$= 9.0 \times 10^{-6} \langle s \rangle \checkmark$ |  | 3 |

(continued...)

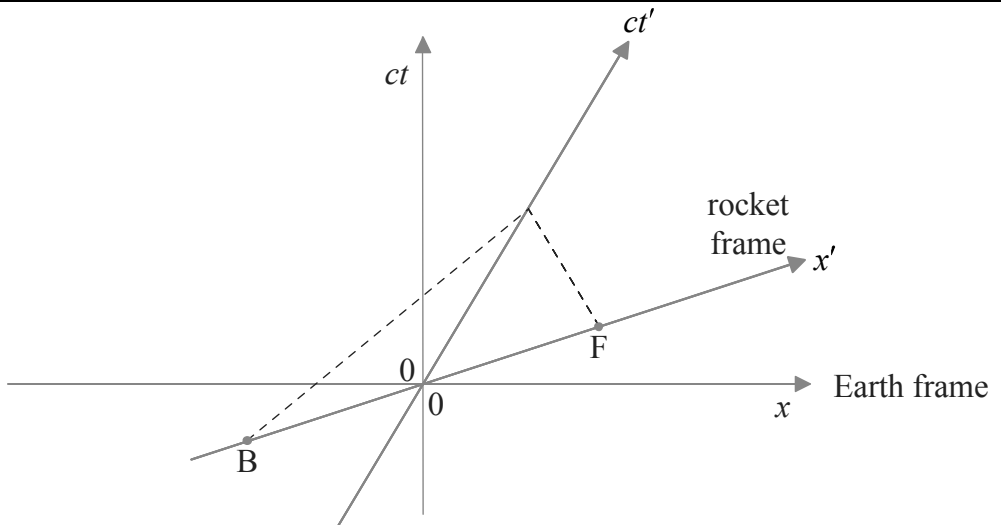

(Question 5 continued)

| Question |     | Answers  | Notes         | Total |
|----------|-----|--|---------------|-------|
| a        | iii | $\Delta x = \langle ct = 3.0 \times 10^8 \times 9.0 \times 10^{-6} \Rightarrow 2700 \langle m \rangle$ <p><b>OR</b></p> $\Delta x = \langle \gamma [\Delta x' + v\Delta t'] \rangle = \frac{5}{3} \left[ 900 + 0.80c \times \frac{900}{c} \right] \Rightarrow 2700 \langle m \rangle \checkmark$ |               | 1     |
| b        | i   |  <p>starting points at B and F ✓</p> <p>ending at the same point on the <math>ct'</math> axis ✓</p> <p>correct slope at <math>45^\circ</math> degrees ✓</p>   | Judge by eye. | 3     |

(continued...)

(Question 5 continued)

| Question |     | Answers  | Notes | Total |
|----------|-----|--|-------|-------|
| b        | ii  | <p>lines through B and F parallel to <math>x</math>-axis ✓<br/>to see that B happened first ✓</p>  |       | 2     |
| b        | iii | $\Delta t = \gamma \left[ \Delta t' + \frac{v\Delta x'}{c^2} \right] \Rightarrow \frac{5}{3} \left[ 0 + \frac{0.80c \times [900]}{c^2} \right] \checkmark$ $\Delta t = 4.0 \times 10^{-6} \text{ <s> } \checkmark$ |       | 2     |
| c        |     | <p>solving for <math>u</math> ✓<br/>correct substitution ✓<br/>correct answer of <math>0.36c</math> ✓</p>  |       | 3     |

| Question |   |    | Answers  | Notes | Total |
|----------|---|----|--|-------|-------|
| 6.       | a |    | $pc = \langle \sqrt{E^2 - [mc^2]^2} \rangle = \langle \sqrt{1070^2 - 135^2} \rangle \checkmark$  |       | 1     |
|          | b |    | energy: $E_X + E_Y = 1070 \langle \text{MeV} \rangle \checkmark$<br>momentum: $E_X - E_Y = 1060 \langle \text{MeV} \rangle \checkmark$<br>solving to get $E_Y = 5 \langle \text{MeV} \rangle \checkmark$   |       | 3     |
| 7.       | a | i  | impossible to distinguish effects of gravity from effects of acceleration<br><b>OR</b><br>frame accelerating in outer space with acceleration $\langle a \rangle$ is equivalent to frame at rest in gravitational field $\langle \text{with } g = a \rangle$<br><b>OR</b><br>frame freely falling in gravitational field is equivalent to inertial frame in outer space $\checkmark$   |       | 1     |
|          | a | ii | <i>version with accelerating frame:</i><br>observer is moving relative to source and so light experiences Doppler shift $\checkmark$<br>motion is away from source and so frequency is reduced $\checkmark$<br>frame is equivalent to frame at rest in a gravitational field $\checkmark$<br><b>OR</b><br><i>version with freely falling frame:</i><br>light received by observer in freely falling frame is blueshifted because of Doppler effect $\checkmark$<br>but frame is equivalent to inertial frame so frequency cannot change $\checkmark$<br>so rising light suffers gravitational redshift $\langle \text{to offset the Doppler blueshift} \rangle \checkmark$ |       | 3     |

(continued...)

(Question 7 continued)

| Question |          | Answers   | Notes | Total    |
|----------|----------|---|-------|----------|
|          | <b>b</b> | $\frac{1}{\sqrt{1 - \frac{1}{1.25}}}$ ✓<br>$= 2.24 \text{ (s)}$ ✓ |       | <b>2</b> |

Option B — Engineering physics

| Question |   | Answers  | Notes  | Total                                |   |
|----------|---|--|--|--------------------------------------|---|
| 8.       | a | $\alpha = \frac{a}{R} \checkmark$ $T \times R = \frac{1}{2} MR^2 \frac{a}{R} \checkmark$ $mg - T = ma \checkmark$ <p>⟨add equations/eliminate tension⟩ to get <math>mg = ma + \frac{1}{2} Ma \checkmark</math></p> |  | 4                                    |   |
|          | b | i  | $a = \left\langle \frac{24 \times 9.8}{24 + \frac{36}{2}} \right\rangle = 5.6 \langle \text{ms}^{-2} \rangle \checkmark$ $v = \langle \sqrt{2as} = \sqrt{2 \times 5.6 \times 16} \rangle = 13.4 \approx 13 \langle \text{ms}^{-1} \rangle \checkmark$ <p><b>OR</b></p> $mgh = \frac{1}{2} mv^2 + \frac{1}{2} I^2 \omega^2$ <p><b>OR</b></p> $mgh = \frac{1}{2} mv^2 + \frac{1}{2} I \frac{v^2}{R^2} \checkmark$ $v = \left\langle \sqrt{\frac{2 \times 24 \times 9.8 \times 16}{24 + 18}} \right\rangle = 13.4 \approx 13 \langle \text{ms}^{-1} \rangle \checkmark$ | Award [2] for a bald correct answer. | 2 |

(continued...)

(Question 8 continued)

| Question |    | Answers   | Notes  | Total |
|----------|----|---|--|-------|
| b        | ii | <p>rate of change of <math>L</math> is <math>I\alpha = I \frac{a}{R}</math> ✓</p> $\left\langle \frac{1}{2} MR^2 \frac{a}{R} \Rightarrow \frac{1}{2} \times 36 \times 0.20 \times \frac{24 \times 9.8}{24 + \frac{36}{2}} \right\rangle$ ✓<br>$= 20.2 \approx 20 \langle \text{N m} \rangle$ ✓<br><br><b>OR</b><br>rate of change of $L$ is $\Gamma$ (torque on axle) ✓<br>$\Gamma = TR = \frac{1}{2} \times 36 \times \frac{24 \times 9.8}{24 + \frac{36}{2}} \times 0.20$ ✓<br>$= 20.2 \approx 20 \langle \text{N m} \rangle$ ✓ | <p><i>Award [3] for a bald correct answer.</i></p> | 3     |
| c        |    | $\langle P = 45 \times 9.8 \times 2.0 \Rightarrow 882 \approx 880 \langle \text{W} \rangle$ ✓   |  | 1     |

| Question |   |     | Answers  | Notes   | Total |
|----------|---|-----|--|---|-------|
| 9.       | a |     | $\langle \text{maximum is at B and so } T_B = 400 \times \frac{8}{2} \Rightarrow 1600 \text{ K} \rangle \checkmark$                                    |   | 1     |
|          | b | i   | $W = \langle p\Delta V \Rightarrow 5.0 \times 10^5 \times [8.0 - 2.0] \times 10^{-3} \checkmark$<br>$W = 3.0 \times 10^3 \text{ J} \rangle \checkmark$ | <i>Award [2] for a bald correct answer.</i>   | 2     |
|          | b | ii  | $\Delta U = \langle \frac{3}{2} p\Delta V = \frac{3}{2} \times 3.0 \times 10^3 \Rightarrow 4.5 \times 10^3 \text{ J} \rangle \checkmark$               | <i>Award [1] for a bald correct answer.</i>   | 1     |
|          | b | iii | $Q = \langle \Delta U + W = 3.0 \times 10^3 + 4.5 \times 10^3 \Rightarrow 7.5 \times 10^3 \text{ J} \rangle \checkmark$                                | <i>Award [1] for a bald correct answer.</i>   | 1     |
|          | c |     | $\Delta S = \frac{Q}{T} = -\frac{1390}{400} \checkmark$<br>$\Delta S = -3.48 \approx -3.5 \text{ JK}^{-1} \rangle \checkmark$                          | <i>Award [1 max] for omitted minus sign.</i><br><i>Award [2] for a bald correct answer.</i> | 2     |
|          | d |     | $e = \frac{3000 - 1390}{7500} \checkmark$<br>$e = 0.21 \checkmark$   | <i>Award [2] for a bald correct answer.</i>   | 2     |
|          | e |     | greater $\checkmark$   |   | 1     |

| Question |   |    | Answers  | Notes   | Total |
|----------|---|----|--|---|-------|
| 10.      | a |    | smooth flow<br><b>OR</b><br>non-turbulent flow<br><b>OR</b><br>flow with low Reynolds number ✓   |   | 1     |
|          | b | i  | reference to $Av = \text{constant}$ ✓<br><br>area ⟨of a flowtube⟩ decreases above the foil / <i>OWTTE</i> ✓  |   | 2     |
|          | b | ii | realization that height plays no role <i>ie.</i> $\frac{1}{2}\rho v_1^2 + p_1 = \frac{1}{2}\rho v_2^2 + p_2$ ✓<br><br>$p_1 - p_2 = \langle \frac{1}{2} \times 0.95 \times [64^2 - 52^2] \Rightarrow 661.2 \langle \text{Pa} \rangle$ ✓<br><br>$L = \langle [p_1 - p_2] A = 661.2 \times 2.0 \Rightarrow 1.3 \langle \text{kN} \rangle$ ✓ | <i>Award [1 max] for an answer of 137 N.<br/>Award [3] for a bald correct answer.</i> | 3     |

| Question |   |    | Answers  | Notes | Total |
|----------|---|----|--|-------|-------|
| 11.      | a |    | $Q = 2\pi \times \frac{4^2}{4^2 - 3^2}$ ✓<br><br>$Q = 14.36 \approx 14$ ✓            |       | 2     |
|          | b | i  | the amplitude will increase ✓  |       | 1     |
|          | b | ii | the phase will approach ⟨negative⟩ $\frac{\pi}{2}$ ⟨relative to the driving force⟩ ✓ |       | 1     |



Option C — Imaging

| Question |   |     | Answers  | Notes                         | Total |
|----------|---|-----|--|-------------------------------|-------|
| 12.      | a | i   | the image would be formed at the focal point of the concave mirror<br><b>OR</b><br>at a distance of 9.50 m from the centre of the concave mirror <since the object distance is very large> ✓<br>$\langle - \rangle \frac{9.50}{u} = \frac{D_i}{D_o}$ ✓<br>$D_i = 9.50 \times \frac{D_o}{u} = 9.50 \times \theta = 9.50 \times 1.40 \times 10^{-4}$ ✓<br>$= 0.00133 \langle \text{m} \rangle$ |                               | 3     |
|          | a | ii  | the object distance is $-[9.50 - 8.57] = -0.93 \langle \text{m} \rangle$ ✓<br>so the magnification is $\frac{8.57}{0.93} = 9.215$ ✓<br>the diameter of this image is then $9.215 \times 0.00133 = 0.012256 \langle \text{m} \rangle$ ✓   | <i>Ignore incorrect sign.</i> | 3     |
|          | a | iii | angle: $\frac{12.3 \langle \text{mm} \rangle}{98.0 \langle \text{mm} \rangle} = 0.126 \langle \text{rad} \rangle$ ✓<br>magnification: $\frac{0.126}{1.40 \times 10^{-4}}$ ✓<br>$= 900$ ✓   |                               | 3     |

(continued...)

(Question 12 continued)

| Question |          |           | Answers  | Notes | Total        |
|----------|----------|-----------|--|-------|--------------|
|          | <b>b</b> | <b>i</b>  | with parabolic mirrors the problem of spherical aberration is eliminated ✓   |       | <b>1</b>     |
|          | <b>b</b> | <b>ii</b> | no chromatic aberration ✓<br>easier/cheaper to make large mirrors than large lenses ✓<br>easier to support and so can be large ✓<br>less absorption in glass ✓   |       | <b>1 max</b> |
|          | <b>c</b> |           | a multitude of sources of EM radiation other than visible light have been discovered<br><b>OR</b><br>comparison of optical and non-optical images can be made ✓<br>thus vastly increasing our understanding of what exists in the universe ✓ |       | <b>2</b>     |

|            |          |            |   |  |          |
|------------|----------|------------|---|--|----------|
| <b>13.</b> | <b>a</b> | <b>i</b>   | $\frac{1}{u} = \frac{1}{f} - \frac{1}{v} = \frac{1}{0.40 \times 10^{-2}} - \frac{1}{20 \times 10^{-2}} \checkmark$  |  | <b>1</b> |
|            | <b>a</b> | <b>ii</b>  | $M = \left\langle -\frac{v}{u} \times \frac{D}{f_e} \right\rangle = -\frac{0.20}{4.1 \times 10^{-3}} \times \frac{0.25}{3.2 \times 10^{-2}} \checkmark$<br>$M = 382.8 \approx 380 \checkmark$ |  | <b>2</b> |
|            | <b>a</b> | <b>iii</b> | $\frac{0.1 \langle \text{mm} \rangle}{380} \approx 260 \langle \text{nm} \rangle \checkmark$  |  | <b>1</b> |
|            | <b>b</b> |            | attenuation = $\langle 4.6 \times 6.2 \rangle = 28.5 \langle \text{dB} \rangle \checkmark$<br>$p = 120 \times 10^{-2.85} \checkmark$<br>power = $0.17 \langle \text{mW} \rangle \checkmark$   |  | <b>3</b> |

| Question |   |     | Answers   | Notes               | Total |
|----------|---|-----|---|---------------------|-------|
| 14.      | a | i   | sharpness is a measure of how easy it is to see edges of different organs or different types of tissue in an image ✓  |                     | 1     |
|          | a | ii  | use as point-like a source as possible<br><b>OR</b><br>reduce backscatter of photons by metal strips ⟨placed along direction of incident X-rays⟩<br><b>OR</b><br>use of computer software to detect and enhance edges ✓ |                     | 1     |
|          | b | i   | they will be absorbed ⟨doing damage⟩ without contributing to forming the image ✓  |                     | 1     |
|          | b | ii  | at 50 keV absorption coefficient is $0.20\text{ cm}^{-1}$ ✓<br>transmitted intensity fraction is $\langle e^{-0.20 \times 2} \Rightarrow 67\% \rangle$ ✓  | <i>Accept 0.67.</i> | 2     |
|          | c | i   | forces protons to make a spin transition ✓  |                     | 1     |
|          | c | ii  | allows determination of the point from which the photons are emitted ✓  |                     | 1     |
|          | c | iii | the proton spin relaxation time depends on the type of tissue at the point where the radiation is emitted ✓   |                     | 1     |
|          | d |     | no harmful ionizing radiation ✓<br>can better distinguish between different parts of the soft tissue ✓  |                     | 2     |

**Option D — Astrophysics**

| Question |   |     | Answers   | Notes   | Total |
|----------|---|-----|---|---|-------|
| 15.      | a |     | helium ✓  |   | 1     |
|          | b | i   | $d = \sqrt{\frac{3.8 \times 10^{27}}{4\pi \times 7.6 \times 10^{-14}}} \checkmark$ $d = 6.3 \times 10^{19} \text{ <m> } \checkmark$ $d = 2000 \text{ <pc> } \checkmark$                                   | <i>Award [3] for a bald correct answer.</i>       | 3     |
|          | b | ii  | no, the distance is too great for the parallax angle to be measured accurately <even from an orbiting telescope> ✓  |   | 1     |
|          | b | iii | $\left[ \frac{M}{M_{\odot}} \right]^{3.5} = 10 \checkmark$ $\frac{M}{M_{\odot}} = \langle 10^{3.5} \Rightarrow \rangle 1.93 \approx 2 \checkmark$   | <i>Award [2] for a bald correct answer.</i>       | 2     |
|          | c | i   | estimates of temperatures for star as 7500 (±200) <K> and Sun as 6000 <K> ✓<br>$10 = \frac{\sigma 4\pi R^2 7500^4}{\sigma 4\pi R_{\odot}^2 6000^4} \checkmark$ $\frac{R}{R_{\odot}} \approx 2 \checkmark$ | <i>Accept answers in the range of 1.9 to 2.1.</i> | 3     |
|          | c | ii  | line starting at correct position [ $T = 7500 \text{ K}, L = 10$ ] and extending into red giants ✓<br>ending at white dwarfs ✓  |   | 2     |
|          | c | iii | equilibrium between gravitational pressure and electron degeneracy pressure ✓<br>provided final mass is below the Chandrasekhar limit/less than $1.4 M_{\odot}$ ✓   |   | 2     |

| Question |   |    | Answers   | Notes   | Total |
|----------|---|----|---|---|-------|
| 16.      | a | i  | the universe is expanding and so wavelengths <like all distances> are being stretched out<br><b>OR</b><br>wavelength increasing hence the Doppler redshift is being observed ✓  | <i>Must mention redshift in alternative answer.</i> | 1     |
|          | a | ii | $\langle z = \frac{v}{c} \Rightarrow \rangle v = 0.157 \times 3.0 \times 10^8 = 4.7 \times 10^4 \langle \text{kms}^{-1} \rangle$ ✓<br><br>$d = \langle \frac{v}{H} = \frac{4.7 \times 10^4}{71} \Rightarrow \rangle 660 \langle \text{Mpc} \rangle$ ✓ | <i>Award [2] for a bald correct answer.</i>         | 2     |
|          | b | i  | gravity is pulling back on the galaxies ✓   |   | 1     |
|          | b | ii | distant supernovae appeared less bright than expected ✓<br><br>indicating that they were further away than expected ✓   |   | 2     |

|     |   |  |   |  |   |
|-----|---|--|---|--|---|
| 17. | a |  | the binding energy per nucleon curve peaks at mass number of about 60 ✓<br>producing heavier elements with fusion is no longer energetically possible ✓   |  | 2 |
|     | b |  | absorption of neutrons by nuclei ✓<br><br>in a slow process in stars ending at the production of bismuth<br><b>OR</b><br>in a fast process in supernovae ending with the very heaviest isotopes<br><beyond bismuth> ✓ |  | 2 |

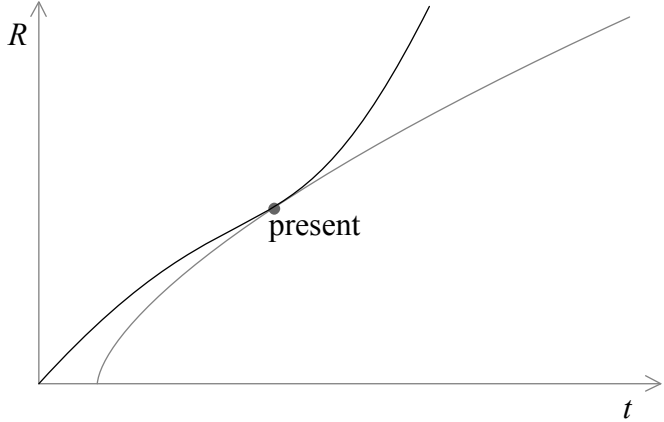
| Question |   | Answers  | Notes  | Total |
|----------|---|--|--|-------|
| 18.      | a | the universe has structure ✓<br>structures only develop if there are fluctuations/differences in density/differences in temperature (which is what the anisotropies in CMB show) ✓ |  | 2     |
|          | b |  <p>graph as shown – does not have to start at the origin ✓</p>                                  |  | 1     |
|          | c | i  | the curve becomes flat ✓   | 1     |
|          | c | ii   | the curve can be used to estimate the mass of the galaxy ✓<br>this mass is greater than the estimate of the mass of the galaxy based on the amount of light radiated ✓ | 2     |



**PHYSICS**  
**STANDARD LEVEL**  
**PAPER 1**

SPECIMEN PAPER

45 minutes

---

INSTRUCTIONS TO CANDIDATES

- Do not open this examination paper until instructed to do so.
- Answer all the questions.
- For each question, choose the answer you consider to be the best and indicate your choice on the answer sheet provided.
- A clean copy of the **Physics Data Booklet** is required for this paper.
- The maximum mark for this examination paper is [30 marks].

1. An object falls freely from rest through a vertical distance of 44.0 m in a time of 3.0 s. What value should be quoted for the acceleration of free-fall?
  - A.  $9.778 \text{ m s}^{-2}$
  - B.  $9.780 \text{ m s}^{-2}$
  - C.  $9.78 \text{ m s}^{-2}$
  - D.  $9.8 \text{ m s}^{-2}$
  
2. What is the order of magnitude for the frequency of visible light?
  - A.  $10^{-15} \text{ Hz}$
  - B.  $10^{-7} \text{ Hz}$
  - C.  $10^9 \text{ Hz}$
  - D.  $10^{15} \text{ Hz}$
  
3. A woman walks due north at  $1 \text{ m s}^{-1}$  before turning through an angle of  $90^\circ$  to travel due east without any change in speed. What is the change, if any, of her velocity?
  - A. No change
  - B.  $1 \text{ m s}^{-1}$  to the west
  - C.  $\sqrt{2} \text{ m s}^{-1}$  to the north east
  - D.  $\sqrt{2} \text{ m s}^{-1}$  to the south east
  
4. A toy car accelerates from rest down an inclined track at  $2.0 \text{ m s}^{-2}$ . What is the speed of the car after 3.0 s?
  - A.  $6.0 \text{ m s}^{-1}$
  - B.  $9.0 \text{ m s}^{-1}$
  - C.  $45 \text{ m s}^{-1}$
  - D.  $54 \text{ m s}^{-1}$



5. A parachutist jumps out of an aircraft and falls freely for a short time, before opening his parachute. Which graph shows the variation of the acceleration  $a$  with time  $t$  of the parachutist from the time he leaves the aircraft until after the parachute is completely open?

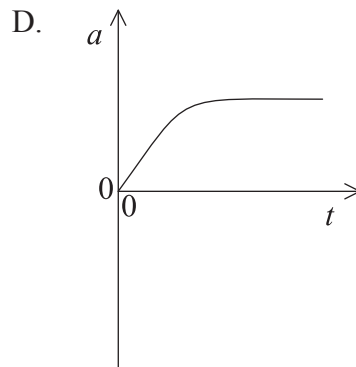
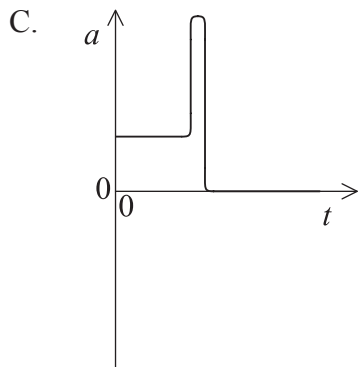
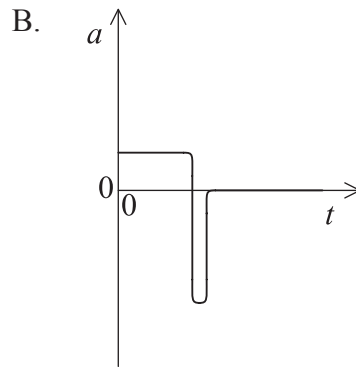
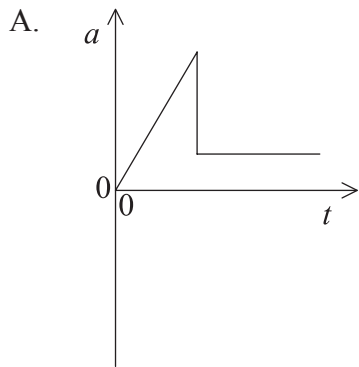

6. A projectile of mass  $m$  is fired from a point P with a velocity having vertical component  $v_v$  and horizontal component  $v_h$ . The projectile reaches point Q as shown in the diagram.

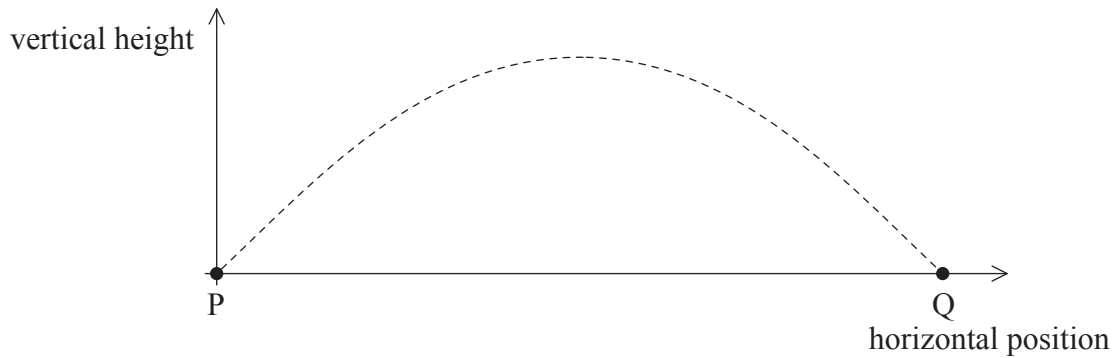

Air resistance on the projectile is negligible. What is the magnitude of the change in momentum of the projectile in moving from P to Q?

- A. Zero
  - B.  $2mv_v$
  - C.  $2mv_h$
  - D.  $2m\sqrt{v_v^2 + v_h^2}$
7. A block of wood is placed on a bench. A variable horizontal force  $F$  is applied to the block, which is initially at rest.

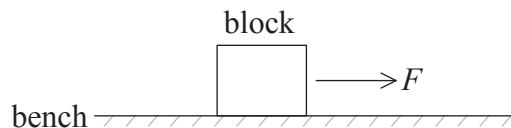

$F$  is initially increased and then adjusted until the block moves at a constant horizontal speed. Which describes  $F$  as the block moves along the bench?

- A. It continues to increase.
- B. It reaches a constant value.
- C. It decreases to zero.
- D. It decreases to a constant value.

8. The pound is a unit of mass equivalent to 0.454 kg. It is used in a limited number of countries but is rarely used by modern scientists. Which statement is correct?
- A. Scientists cannot be sure that all other scientists will be able to work in pounds.
  - B. The pound cannot be defined precisely enough to be used.
  - C. The pound is too large a unit to be used for most masses.
  - D. The pound cannot be divided into metric portions.
9. A rocket is made up of two stages, the main rocket of mass  $M$  and a booster rocket of mass  $m$ . While moving freely in space with a velocity  $v$ , the booster rocket disconnects from the main rocket leaving the booster rocket stationary. What is the velocity of the main rocket?
- A.  $\frac{mv}{M - m}$
  - B.  $\frac{Mv}{M - m}$
  - C.  $\frac{Mv}{M + m}$
  - D.  $\frac{(M + m)v}{M}$

10. An electrical heater of power 12 W is immersed in a liquid of mass 0.2 kg. The graph shows the variation of the temperature  $\theta$  of the liquid with time  $t$ .

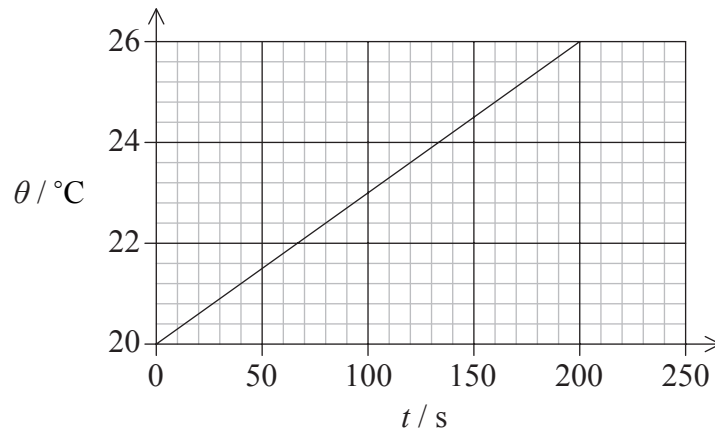

What is the value for the specific heat capacity of the liquid?

- A.  $20 \text{ J kg}^{-1} \text{ K}^{-1}$
  - B.  $500 \text{ J kg}^{-1} \text{ K}^{-1}$
  - C.  $2000 \text{ J kg}^{-1} \text{ K}^{-1}$
  - D.  $12\,000 \text{ J kg}^{-1} \text{ K}^{-1}$
11. A balloon develops a tiny hole and molecules leak into the surrounding air. The temperature is unchanged. The initial volume and pressure of the balloon are  $V_0$  and  $p_0$ . How are the new volume and pressure of the balloon related to the initial values?

|    | Volume  | Pressure |
|----|---------|----------|
| A. | $< V_0$ | $< p_0$  |
| B. | $< V_0$ | $p_0$    |
| C. | $V_0$   | $< p_0$  |
| D. | $V_0$   | $p_0$    |

12. The graph shows the variation with volume  $V$  of the pressure  $p$  of a fixed mass of an ideal gas as the temperature of the gas is raised.

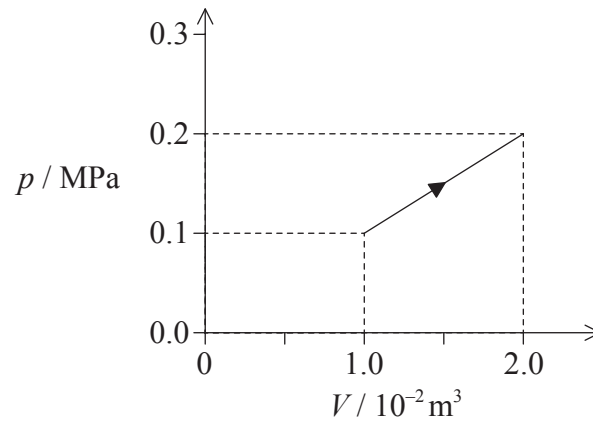

What is the work done by the gas during the process?

- A. 0.5 kJ
- B. 1.0 kJ
- C. 1.5 kJ
- D. 2.0 kJ

13. The diagram shows a simple pendulum undergoing simple harmonic motion between positions X and Z. Y is the rest position of the pendulum.

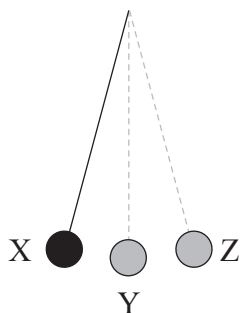

Which describes the magnitude of linear acceleration and linear speed for the pendulum bob?

|    | <b>Linear acceleration</b> | <b>Linear speed</b> |
|----|----------------------------|---------------------|
| A. | zero at Y                  | zero at Y           |
| B. | maximum at X and Z         | zero at X and Z     |
| C. | maximum at X and Z         | maximum at X and Z  |
| D. | zero at X and Z            | maximum at X and Z  |

14. Some of the properties that can be demonstrated using waves are

- I. refraction
- II. polarization
- III. diffraction.

Which properties can be demonstrated using **sound** waves?

- A. I and II only
- B. I and III only
- C. II only
- D. III only

15. The amplitude of a wave at a certain distance for a source is  $A$  and its intensity is  $I$ . At this position the amplitude increases to  $4A$ . What is the intensity of the wave?
- A.  $I$
- B.  $2I$
- C.  $4I$
- D.  $16I$
16. Light travels with speed  $v$  and wavelength  $\lambda$  in a medium of refractive index  $n_1$ . The light then enters a second medium of refractive index  $n_2$ . What is the speed and the wavelength of the wave in the second medium?

|    | Speed               | Wavelength                |
|----|---------------------|---------------------------|
| A. | $v \frac{n_1}{n_2}$ | $\lambda \frac{n_1}{n_2}$ |
| B. | $v \frac{n_1}{n_2}$ | $\lambda \frac{n_2}{n_1}$ |
| C. | $v \frac{n_2}{n_1}$ | $\lambda \frac{n_1}{n_2}$ |
| D. | $v \frac{n_2}{n_1}$ | $\lambda \frac{n_2}{n_1}$ |

17. The diagram shows two pipes of equal length. Pipe X is open at both ends and pipe Y is closed at one end.



Which is correct about the harmonics that each pipe can produce?

|    | Pipe X             | Pipe Y             |
|----|--------------------|--------------------|
| A. | all harmonics      | all harmonics      |
| B. | all harmonics      | odd harmonics only |
| C. | odd harmonics only | all harmonics      |
| D. | odd harmonics only | odd harmonics only |

18. Two wires of different diameters are made from the same metal. The wires are connected in series with a cell. Which quantity will be **smaller** in the **thicker** wire?
- A. The current
  - B. The drift velocity of the electrons
  - C. The number of free electrons per unit volume
  - D. The number of free electrons passing through any cross-section of the wire per second
19. A heating coil is connected to a battery of electromotive force (emf) 10 V and negligible internal resistance. The power dissipated in the coil is 25 W. What is the resistance of the coil?
- A.  $0.25 \Omega$
  - B.  $2.5 \Omega$
  - C.  $4.0 \Omega$
  - D.  $250 \Omega$



20. Two identical cells, each of emf  $1.6\text{ V}$  and internal resistance  $2.0\ \Omega$ , are connected in parallel with a  $3.0\ \Omega$  resistor.

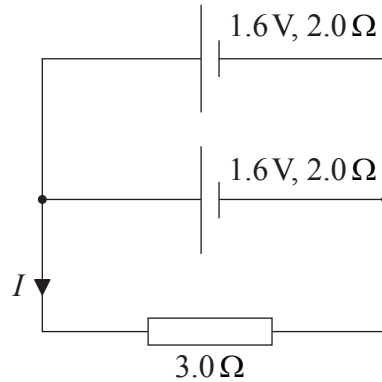

What is the current  $I$ ?

- A. 0.4 A
  - B. 0.6 A
  - C. 0.8 A
  - D. 1.6 A
21. A current-carrying conductor is at right angles to a magnetic field. The force on the conductor is  $F$ . The conductor is turned so that it is parallel to the field with no other changes. In what way, if any, does the force on the conductor change?
- A. It is unchanged.
  - B. It increases so that it is greater than  $F$ .
  - C. It decreases so that it is greater than zero but less than  $F$ .
  - D. It becomes zero.

22. An astronaut orbits the Earth in a space capsule. Which statement is correct?
- A. There are no gravitational forces acting on the space capsule or the astronaut.
  - B. The space capsule and the astronaut each have the same acceleration.
  - C. The space capsule and the astronaut are each in equilibrium.
  - D. The gravitational force on the space capsule is equal to that on the astronaut.
23. The table shows four of the energy levels for the hydrogen atom with their corresponding energies.

| Energy level | Energy / $10^{-19}$ J |
|--------------|-----------------------|
| 6            | –0.6                  |
| 4            | –1.4                  |
| 2            | –5.4                  |
| 1            | –21.8                 |

When an electron changes from level 6 to level 1 the spectral line emitted has a wavelength of  $9.4 \times 10^{-8}$  m. What is the approximate wavelength of the spectral line emitted when an electron changes from level 4 to level 2?

- A.  $5 \times 10^{-4}$  m
  - B.  $5 \times 10^{-7}$  m
  - C.  $5 \times 10^{-8}$  m
  - D.  $5 \times 10^{-10}$  m
24. All isotopes of a particular element have the same
- A. mode of radioactive decay.
  - B. half-life.
  - C. number of protons.
  - D. number of neutrons.

25. The magnitude of the binding energy per nucleon is
- A. a maximum for nuclides having nucleon numbers around 60.
  - B. directly proportional to the neutron to proton ratio of nuclides.
  - C. a maximum for nuclides with high nuclear charges.
  - D. a maximum for nuclides with low nuclear charges.

26. A positive pion is a meson consisting of an up quark and an anti-down quark. A student suggests that the decay of the positive pion is represented by the following equation.

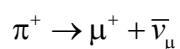

The suggestion is incorrect because one of the quantities is not conserved. Which quantity is **not** conserved in the student's equation?

- A. Charge
  - B. Baryon number
  - C. Lepton number
  - D. Strangeness
27. The blade length of a wind turbine is doubled. By what factor will the maximum power output increase?
- A. 2
  - B. 4
  - C. 8
  - D. 16

28. The Sankey diagram shows a typical fossil-fuel plant of total efficiency 40%. There are frictional, electrical transmission and energy losses to the lower temperature surroundings. Which branch represents energy losses to the surroundings?

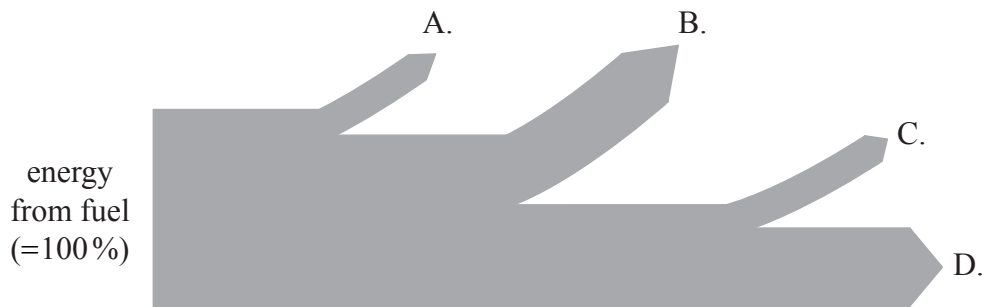

29. The absolute temperature of a black body increases by 2%. What is the percentage increase in the power emitted by the black body?
- A. 2
  - B. 4
  - C. 8
  - D. 16
30. What is thermal conduction mainly due to in a gas?
- A. The motion of free electrons
  - B. Fast molecules transferring energy to slower molecules
  - C. Slow molecules transferring energy to faster molecules
  - D. Lattice vibrations causing collisions with neighbouring molecules
-



# **MARKSCHEME**

## **SPECIMEN PAPER 2016**

### **PHYSICS**

#### **Standard Level**

#### **Paper 1**

- |     |          |     |          |     |          |     |          |
|-----|----------|-----|----------|-----|----------|-----|----------|
| 1.  | <u>D</u> | 16. | <u>A</u> | 31. | <u>-</u> | 46. | <u>-</u> |
| 2.  | <u>D</u> | 17. | <u>B</u> | 32. | <u>-</u> | 47. | <u>-</u> |
| 3.  | <u>D</u> | 18. | <u>B</u> | 33. | <u>-</u> | 48. | <u>-</u> |
| 4.  | <u>A</u> | 19. | <u>C</u> | 34. | <u>-</u> | 49. | <u>-</u> |
| 5.  | <u>B</u> | 20. | <u>A</u> | 35. | <u>-</u> | 50. | <u>-</u> |
| 6.  | <u>B</u> | 21. | <u>D</u> | 36. | <u>-</u> | 51. | <u>-</u> |
| 7.  | <u>D</u> | 22. | <u>B</u> | 37. | <u>-</u> | 52. | <u>-</u> |
| 8.  | <u>A</u> | 23. | <u>B</u> | 38. | <u>-</u> | 53. | <u>-</u> |
| 9.  | <u>D</u> | 24. | <u>C</u> | 39. | <u>-</u> | 54. | <u>-</u> |
| 10. | <u>C</u> | 25. | <u>A</u> | 40. | <u>-</u> | 55. | <u>-</u> |
| 11. | <u>B</u> | 26. | <u>C</u> | 41. | <u>-</u> | 56. | <u>-</u> |
| 12. | <u>C</u> | 27. | <u>B</u> | 42. | <u>-</u> | 57. | <u>-</u> |
| 13. | <u>B</u> | 28. | <u>B</u> | 43. | <u>-</u> | 58. | <u>-</u> |
| 14. | <u>B</u> | 29. | <u>C</u> | 44. | <u>-</u> | 59. | <u>-</u> |
| 15. | <u>D</u> | 30. | <u>B</u> | 45. | <u>-</u> | 60. | <u>-</u> |

**PHYSICS  
STANDARD LEVEL  
PAPER 2**

SPECIMEN PAPER

1 hour 15 minutes

Candidate session number

|  |  |  |  |  |  |  |  |  |  |
|--|--|--|--|--|--|--|--|--|--|
|  |  |  |  |  |  |  |  |  |  |
|--|--|--|--|--|--|--|--|--|--|

Examination code

|  |  |  |  |  |  |  |  |
|--|--|--|--|--|--|--|--|
|  |  |  |  |  |  |  |  |
|--|--|--|--|--|--|--|--|

## INSTRUCTIONS TO CANDIDATES

- Write your session number in the boxes above.
- Do not open this examination paper until instructed to do so.
- Answer all questions.
- Write your answers in the boxes provided.
- A calculator is required for this paper.
- A clean copy of the **Physics Data Booklet** is required for this paper.
- The maximum mark for this examination paper is [50 marks].



Answer **all** questions. Write your answers in the boxes provided.

1. In the drop tower shown, containers with experiments inside of them are fired upwards inside a vertical tower.

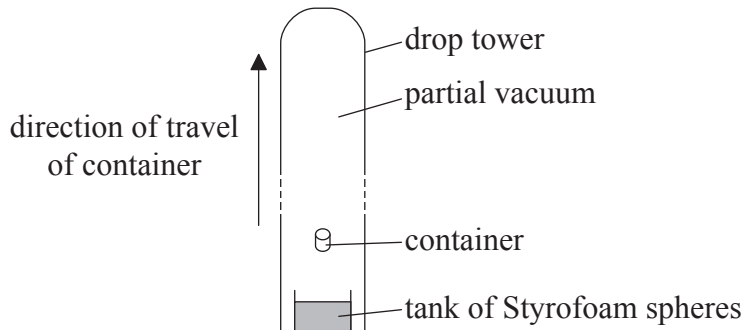

The container moves under the influence of gravity and eventually falls back to the bottom of the tower. Most of the air is removed from the tower so that air resistance is negligible. While in flight, the container and its contents are in free-fall.

- (a) The container is fired vertically upwards with initial speed  $48 \text{ m s}^{-1}$ . Determine the time that the container is in flight. [2]

.....  
.....  
.....  
.....  
.....  
.....

(This question continues on the following page)





*(Question 1 continued)*

- (b) At the end of the flight, the container of total mass 480 kg falls into a tank of expanded Styrofoam (polystyrene) spheres to slow it. The container stops after moving a distance of 8.0 m in the Styrofoam. Calculate the average force that acts on the container due to the spheres. [3]

.....

.....

.....

.....

.....

.....

- (c) Outline why the experiments inside the container could be considered to be in “weightless” conditions. [2]

.....

.....

.....

.....

*(This question continues on the following page)*



*(Question 1 continued)*

(d) The tower is 120m high with an internal diameter of 3.5 m. When most of the air has been removed, the pressure in the tower is 0.96 Pa.

(i) Determine the number of molecules of air in the tower when the temperature of the air is 300 K. [3]

.....

.....

.....

.....

.....

.....

(ii) Outline whether the behaviour of the remaining air in the tower approximates to that of an ideal gas. [2]

.....

.....

.....

.....

*(This question continues on the following page)*



(Question 1 continued)

- (e) The container can also be released from rest at the top of the tower. The graph shows how the container velocity varies with time from release with the tower in a partial vacuum.

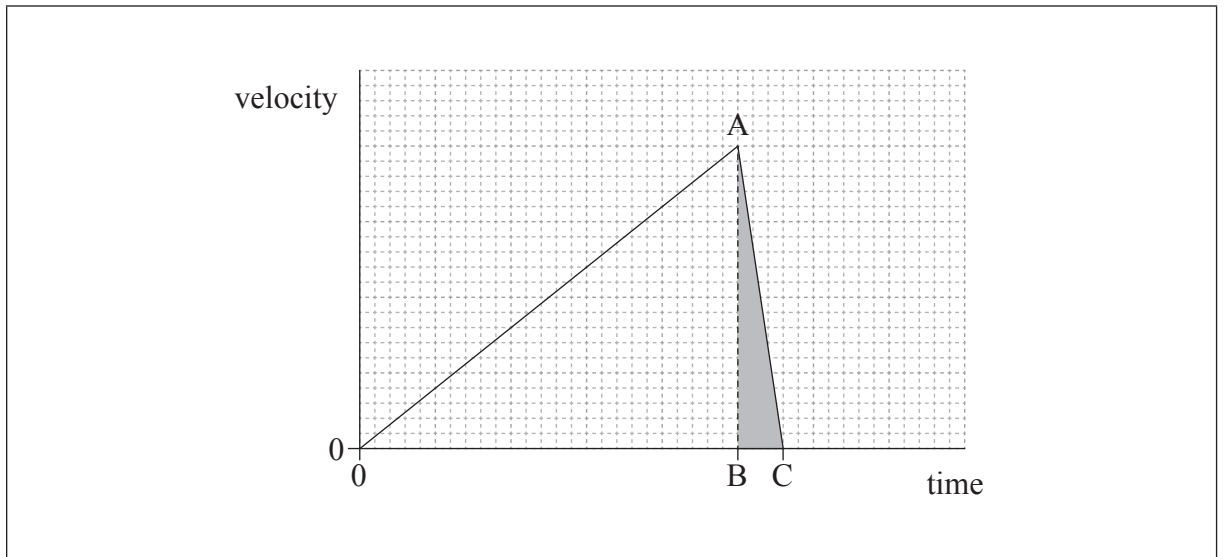

- (i) State the quantity that is represented by the shaded area ABC. [1]

.....

- (ii) Air is introduced into the tower. The container is released from the top of the tower when the air in the tower is at atmospheric pressure. Using the axes in (e), sketch a graph to show how the container velocity varies with time from release when the air is at atmospheric pressure. [3]



2. (a) State Ohm's law.

[1]

.....  
.....

(b) (i) A copper wire has a length of 0.20 km and a diameter of 3.0 mm. The resistivity of copper is  $1.7 \times 10^{-8} \Omega \text{m}$ . Determine the resistance of the wire.

[3]

.....  
.....  
.....  
.....  
.....  
.....

(ii) A potential difference of 6.0 V is maintained across the ends of the wire. Calculate the power dissipated in the wire.

[1]

.....  
.....

(iii) Explain how the flow of electrons in the wire leads to an increase in the temperature of the wire.

[3]

.....  
.....  
.....  
.....  
.....



3. A loudspeaker emits sound waves of a single frequency towards a reflecting barrier.

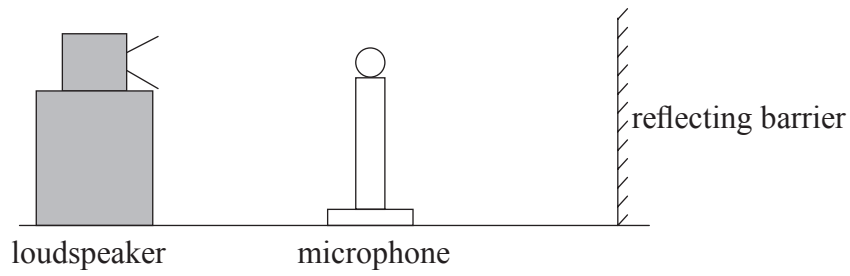

A microphone is moved along a straight line between the loudspeaker and the barrier. A sequence of equally spaced maxima and minima of sound wave intensity is detected.

(a) Explain how the maxima and minima are formed.

[4]

.....

.....

.....

.....

.....

.....

*(This question continues on the following page)*



(Question 3 continued)

(b) The microphone is moved through 1.0m from one point of minimum intensity to another point of minimum intensity. It passes through seven points of maximum intensity as it moves. The speed of sound is  $340\text{ m s}^{-1}$ .

(i) Calculate the wavelength of the sound waves. [2]

.....  
.....  
.....  
.....

(ii) Outline how you could use this arrangement to determine the speed of sound in air. [3]

.....  
.....  
.....  
.....  
.....  
.....  
.....  
.....



4. (a) A power station burns natural gas at a rate of  $35 \text{ kg s}^{-1}$ . The power output of the station is 750 MW and the efficiency of the station is 38%.

(i) Calculate the energy provided by the natural gas each second. [1]

.....  
.....  
.....  
.....

(ii) Calculate the specific energy of the natural gas. State appropriate units for your answer. [3]

.....  
.....  
.....  
.....

(b) Outline why much of the world's energy is provided from fossil fuels. [2]

.....  
.....  
.....  
.....

*(This question continues on the following page)*



*(Question 4 continued)*

(c) There is a suggestion that the temperature of the Earth may increase if the use of fossil fuels is not reduced over the coming years.

(i) Explain, with reference to the enhanced greenhouse effect, why this temperature increase may occur. [3]

.....

.....

.....

.....

.....

.....

.....

.....

.....

(ii) Outline how scientists continue to attempt to resolve the climate change debate. [1]

.....

.....

.....

.....

*(This question continues on the following page)*





(Question 4 continued)

- (d) Nuclear power stations are one way in which energy can be generated without the use of fossil fuels. One example of a nuclear fission reaction is as shown.

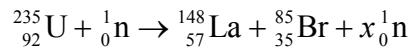

- (i) Identify the value of  $x$ . [1]

.....

- (ii) The following data are available.

Mass of U-235 = 235.044 u  
Mass of n = 1.009 u  
Mass of La-148 = 148.932 u  
Mass of Br-85 = 84.910 u

Determine, in MeV, the energy released when one uranium nucleus undergoes nuclear fission in the reaction in (d). [3]

.....  
.....  
.....  
.....  
.....  
.....

*(This question continues on the following page)*



*(Question 4 continued)*

- (iii) Outline, with reference to the speed of the neutrons, the role of the moderator in a nuclear reactor.

[3]

.....

.....

.....

.....

.....

.....

---

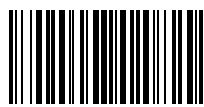



# **MARKSCHEME**

## **SPECIMEN PAPER**

### **PHYSICS**

#### **Standard Level**

#### **Paper 2**

## General Marking Instructions

### Subject Details: Physics SL Paper 2 Markscheme

#### Mark Allocation

Candidates are required to answer **ALL** questions. Maximum total = **[50 marks]**.

#### Markscheme format example:

| Question |   |    | Answers   | Notes                                 | Total |
|----------|---|----|---|---------------------------------------|-------|
| 4.       | b | ii | the displacement and acceleration ✓<br>are in opposite directions ✓ | <i>Accept force for acceleration.</i> | 2     |

- Each row in the “Question” column relates to the smallest subpart of the question.
- The maximum mark for each question subpart is indicated in the “Total” column.
- Each marking point in the “Answers” column is shown by means of a tick (✓) at the end of the marking point.
- A question subpart may have more marking points than the total allows. This will be indicated by “**max**” written after the mark in the “Total” column. The related rubric, if necessary, will be outlined in the “Notes” column.
- An alternative wording is indicated in the “Answers” column by a slash (/). Either wording can be accepted.
- An alternative answer is indicated in the “Answers” column by “**OR**” on the line between the alternatives. Either answer can be accepted.
- Words in angled brackets < > in the “Answers” column are not necessary to gain the mark.
- Words that are underlined are essential for the mark.
- The order of marking points does not have to be as in the “Answers” column, unless stated otherwise in the “Notes” column.
- If the candidate’s answer has the same “meaning” or can be clearly interpreted as being of equivalent significance, detail and validity as that in the “Answers” column then award the mark. Where this point is considered to be particularly relevant in a question it is emphasized by **OWTTE** (or words to that effect) in the “Notes” column.
- Remember that many candidates are writing in a second language. Effective communication is more important than grammatical accuracy.

12. Occasionally, a part of a question may require an answer that is required for subsequent marking points. If an error is made in the first marking point then it should be penalized. However, if the incorrect answer is used correctly in subsequent marking points then **follow through** marks should be awarded. When marking, indicate this by adding **ECF** (error carried forward) on the script. “ECF acceptable” will be displayed in the “Notes” column.
13. Do **not** penalize candidates for errors in units or significant figures, **unless** it is specifically referred to in the “Notes” column.

| Question |   | Answers  | Notes   | Total   |
|----------|---|--|---|---|
| 1.       | a | use of suitable kinematic equation eg: $-48 = 48 - 9.81t$ ✓<br>$9.8 \langle s \rangle$ ✓   | <i>Award [2] for a bald correct answer.</i>   | 2   |
|          | b | $0 = 48^2 - 2a8$ so $a = 144 \langle \text{ms}^{-2} \rangle$ ✓<br>$F_{\text{net}} = 480 \times 144 \langle = 6.9 \times 10^4 \rangle$ ✓<br>average force $\langle = 6.9 \times 10^4 + 0.47 \times 10^4 \rangle = 7.4 \times 10^4 \langle \text{N} \rangle$ ✓ |   | 3   |
|          | c | reaction force is zero ✓<br>because object and container fall at same rate ✓   |   | 2   |
|          | d | i  | volume = $120 \times \pi \times (3.5)^2 = 4620 \langle \text{m}^3 \rangle$ ✓<br>$n = \frac{0.96 \times \text{volume}}{(8.31 \times 300)} = 1.78$ ✓<br>number of molecules = $6.02 \times 10^{23} \times n = 1.1 \times 10^{24}$ ✓ | 3   |
|          | d | ii   | $\langle \text{yes} \rangle$<br>because pressure is low ✓<br>and temperature is high/moderate ✓   | 2   |
|          | e | i  | stopping distance $\langle \text{in polystyrene} \rangle / 8 \text{ m}$ ✓   | <i>Do not accept distance unqualified.</i><br>1         |
|          | e | ii   | gradient decreases as time increases before hitting the polystyrene ✓<br>lower maximum ✓<br>graph must go on longer before deceleration ✓<br>same total area by eye ✓   | <i>Accept a graph reaching terminal speed.</i><br>3 max |

| Question |   |     | Answers   | Notes | Total |
|----------|---|-----|---|-------|-------|
| 2.       | a |     | $V$ proportional to $I$ providing temperature/physical conditions are constant ✓  |       | 1     |
|          | b | i   | use of $A = \langle \frac{\pi d^2}{4} \Rightarrow 7.1 \times 10^{-6} \langle \text{m}^2 \rangle \checkmark$<br>use of $R = \frac{\rho l}{A} \checkmark$<br>0.48 $\langle \Omega \rangle \checkmark$ |       | 3     |
|          | b | ii  | 75 $\langle \text{W} \rangle \checkmark$  |       | 1     |
|          | b | iii | electron collisions with lattice ions ✓<br>loss of kinetic energy of electrons ✓<br>increase of internal energy of lattice ions ✓   |       | 3     |

| Question |   | Answers  | Notes   | Total   |       |
|----------|---|--|---|---|-------|
| 3.       | a | travelling sound wave <is reflected at the barrier and> travels in opposite direction to original wave ✓<br>mention of interference/superposition ✓<br>minima caused by destructive interference ✓<br>maxima caused by constructive interference ✓<br><b>OR</b><br>travelling sound wave <reflects at the barrier and> travels in opposite direction to original wave ✓<br>reflected wave superposes with original wave ✓<br>forming a standing wave ✓<br>maxima are positions of antinodes, minima are positions of nodes ✓ |   | 4   |       |
|          | b | i  | recognition that 3.5 wavelengths are covered ✓<br>0.29 <m> ✓  | 2   |       |
|          | b | ii   | measure each position of several minima/maxima using a ruler ✓<br>use data to determine mean wavelength ✓<br>measure frequency of waves using <i>eg</i> : oscilloscope/frequency meter/electronic guitar tuner ✓<br>use of $c = f\lambda$ ✓ | Accept look up wave frequency or read from apparatus. | 3 max |



| Question |   |     | Answers  | Notes  | Total |
|----------|---|-----|--|--|-------|
| 4.       | a | i   | power = $\langle \frac{7.5 \times 10^8 \times 100}{38} \Rightarrow 1.97 \times 10^9 \text{ J s}^{-1} \rangle \checkmark$   |  | 1     |
|          | a | ii  | $\frac{1.97 \times 10^9}{35} \checkmark$<br>56 $\checkmark$<br>MJ kg <sup>-1</sup> $\checkmark$  |  | 3     |
|          | b |     | plentiful supplies at present $\checkmark$<br>pre-existing infrastructure $\checkmark$   | <i>Accept easily portable, easily mined.</i> | 2     |
|          | c | i   | increased proportion of greenhouse gases in atmosphere $\checkmark$<br>so more absorption of infrared by atmosphere $\checkmark$<br>and extra energy radiated back to ground $\checkmark$  | <i>Accept any named greenhouse gas.</i>      | 3     |
|          | c | ii  | improved modelling<br><b>OR</b><br>greater data collection<br><b>OR</b><br>greater international collaboration $\checkmark$  |  | 1 max |
|          | d | i   | $\langle 235 + 1 - 148 - 85 \Rightarrow 3 \rangle \checkmark$  |  | 1     |
|          | d | ii  | mass difference = $\langle 148.932 + 84.910 + (2 \times 1.009) - 235.044 \rangle \checkmark$<br>$= 0.816 \text{ u} \checkmark$<br>760 MeV $\checkmark$   | <i>Allow ECF from (d)(i).</i>                | 3     |
|          | d | iii | neutrons emitted from uranium at high speed $\checkmark$<br>high speed neutrons do not cause fission $\checkmark$<br>neutrons collide with moderator atoms $\checkmark$<br>and therefore lose energy/speed before re-entering fuel rods $\checkmark$ |  | 3 max |





**PHYSICS**  
**STANDARD LEVEL**  
**PAPER 3**

Candidate session number

|  |  |  |  |  |  |  |  |  |  |
|--|--|--|--|--|--|--|--|--|--|
|  |  |  |  |  |  |  |  |  |  |
|--|--|--|--|--|--|--|--|--|--|

SPECIMEN PAPER

Examination code

1 hour

|  |  |  |  |  |  |  |  |
|--|--|--|--|--|--|--|--|
|  |  |  |  |  |  |  |  |
|--|--|--|--|--|--|--|--|

## INSTRUCTIONS TO CANDIDATES

- Write your session number in the boxes above.
- Do not open this examination paper until instructed to do so.
- Section A: answer all questions.
- Section B: answer all of the questions from one of the options.
- Write your answers in the boxes provided.
- A calculator is required for this paper.
- A clean copy of the **Physics Data Booklet** is required for this paper.
- The maximum mark for this examination paper is [35 marks].

| Option                         | Questions |
|--------------------------------|-----------|
| Option A — Relativity          | 4 – 5     |
| Option B — Engineering physics | 6 – 7     |
| Option C — Imaging             | 8 – 9     |
| Option D — Astrophysics        | 10 – 11   |



SECTION A

Answer **all** questions. Write your answers in the boxes provided.

1. The speed of sound in air,  $v$ , was measured at temperatures near  $0^\circ\text{C}$ . The graph shows the data and the line of best-fit. The error bars for temperature are too small to be shown.

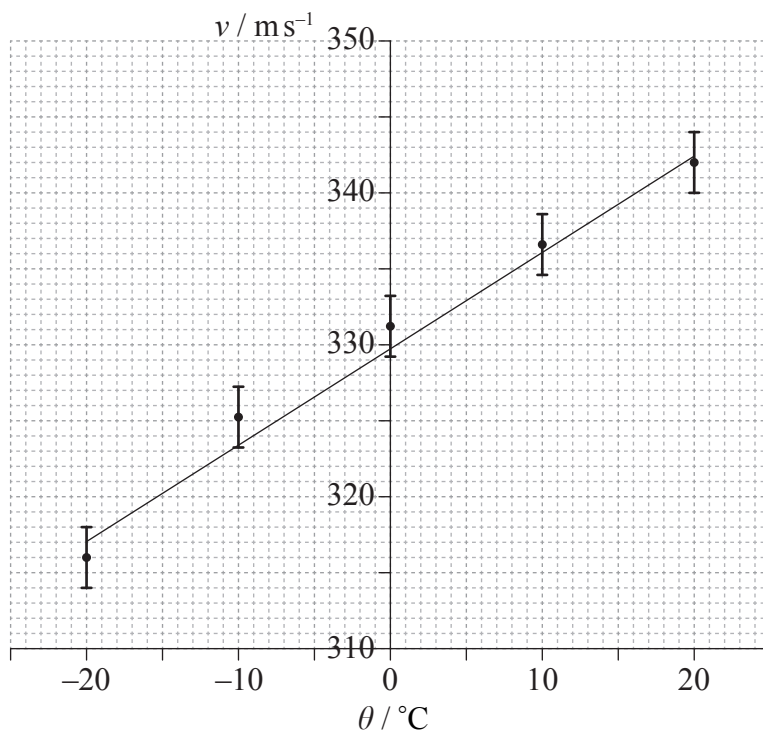

A student suggests that the speed of sound  $v$  is related to the temperature  $\theta$  in degrees Celsius by the equation

$$v = a + b\theta$$

where  $a$  and  $b$  are constants.

- (a) (i) Determine the value of the constant  $a$ , correct to two significant figures. [1]

.....

(This question continues on the following page)



(Question 1 continued)

- (ii) Estimate the absolute uncertainty in  $b$ . [3]

.....  
.....  
.....  
.....

- (iii) A student calculates that  $b = 0.593 \text{ ms}^{-1} \text{ }^\circ\text{C}^{-1}$ . State, using your answer to (a)(ii), the value of  $b$  to the correct number of significant figures. [1]

.....

- (b) (i) Estimate the temperature at which the speed of sound is zero. [1]

.....  
.....

- (ii) Explain, with reference to your answer in (b)(i), why the student's suggestion is not valid. [2]

.....  
.....  
.....  
.....



2. A student uses an electronic timer in an attempt to estimate the acceleration of free-fall  $g$ . She measures the time  $t$  taken for a small metal ball to fall through a height  $h$  of 0.50 m. The percentage uncertainty in the measurement of time is 0.3% and the percentage uncertainty height is 0.6%.

(a) Using  $h = \frac{1}{2}gt^2$ , calculate the expected percentage uncertainty in the value of  $g$ . [1]

.....  
.....  
.....  
.....

(b) State and explain how the student could obtain a more reliable value for  $g$ . [3]

.....  
.....  
.....  
.....  
.....  
.....



3. In an experiment to measure the specific heat capacity of a metal, a piece of metal is placed inside a container of boiling water at 100°C. The metal is then transferred into a calorimeter containing water at a temperature of 10°C. The final equilibrium temperature of the water was measured. One source of error in this experiment is that a small mass of boiling water will be transferred to the calorimeter along with the metal.

(a) Suggest the effect of the error on the measured value of the specific heat capacity of the metal. [2]

.....  
.....  
.....  
.....

(b) State **one** other source of error for this experiment. [1]

.....  
.....



**SECTION B**

Answer *all* of the questions from *one* of the options. Write your answers in the boxes provided.

**Option A — Relativity**

4. (a) Einstein discovered a discrepancy, related to the speed of light, between Maxwell's equations of electromagnetism and Newtonian mechanics. Outline the discrepancy and how Einstein dealt with it. [2]

|       |
|-------|
| ..... |
| ..... |
| ..... |
| ..... |
| ..... |

*(Option A continues on the following page)*





(Option A, question 4 continued)

- (b) A proton enters a region of uniform magnetic field which is directed into the plane of the page as shown.



Reference frame S is at rest with respect to the magnetic field. The speed of the proton is measured to be  $v$  in S.

- (i) State the nature of the force on the proton according to an observer in S. [1]

.....

- (ii)  $S'$  is a reference frame in which the proton is at rest. State and explain whether, according to an observer in  $S'$ , there is a force on the proton. [2]

.....  
.....  
.....  
.....

(Option A continues on the following page)



(Option A continued)

5. A rocket of proper length 900 m is moving at speed  $0.80c$  relative to the Earth. E is a reference frame in which the Earth is at rest. R is a reference frame in which the rocket is at rest. The diagram is from the point of view of E.

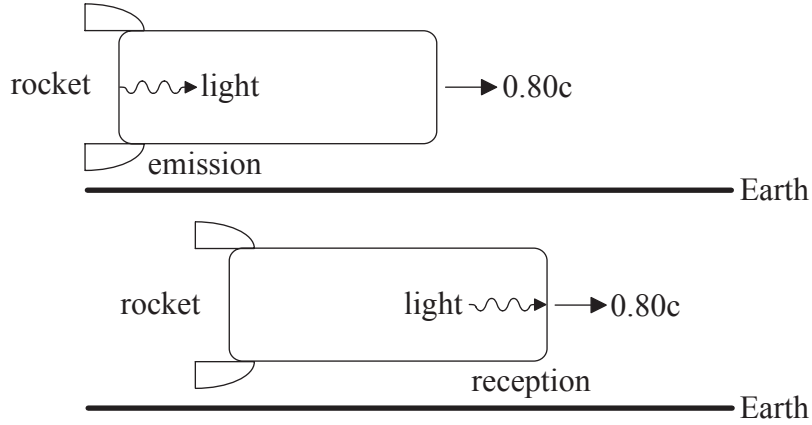

- (a) A light signal is emitted from the back of the rocket and is received at the front of the rocket.

Determine the

- (i) time interval between the emission and reception of the light signal according to an observer in R. [1]

.....

.....

- (ii) time interval between the emission and reception of the light signal according to an observer in E. [3]

.....

.....

.....

.....

(Option A continues on the following page)



*(Option A, question 5 continued)*

- (iii) distance separating the emission and reception of the light signal according to an observer in E.

[1]

.....

.....

.....

.....

*(Option A continues on the following page)*



28EP09

**Turn over**

(Option A, question 5 continued)

- (b) One photon is emitted from the back B of the rocket and another photon is emitted from the front F of the rocket, as shown.

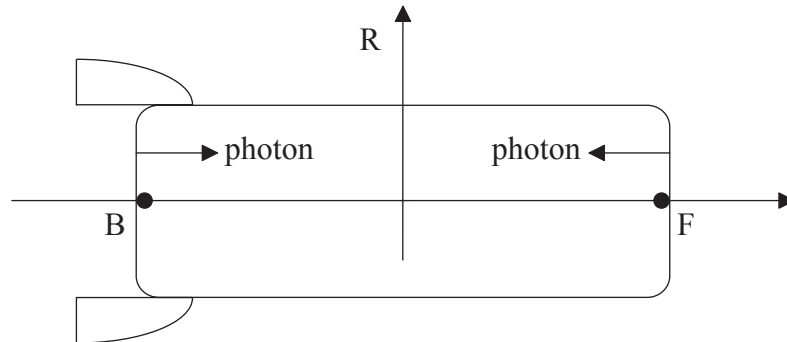

The emissions are simultaneous according to observers in R. The photons are received by an observer at rest in the middle of the rocket.

The spacetime diagram represents the reference frame of the Earth E and the rocket frame R. The coordinates in frame E are  $x$  and  $ct$  and in frame R they are  $x'$  and  $ct'$ . The position of the back B and of the front F of the rocket at  $t' = 0$  are labelled. The origin of the axes corresponds to the middle of the rocket.

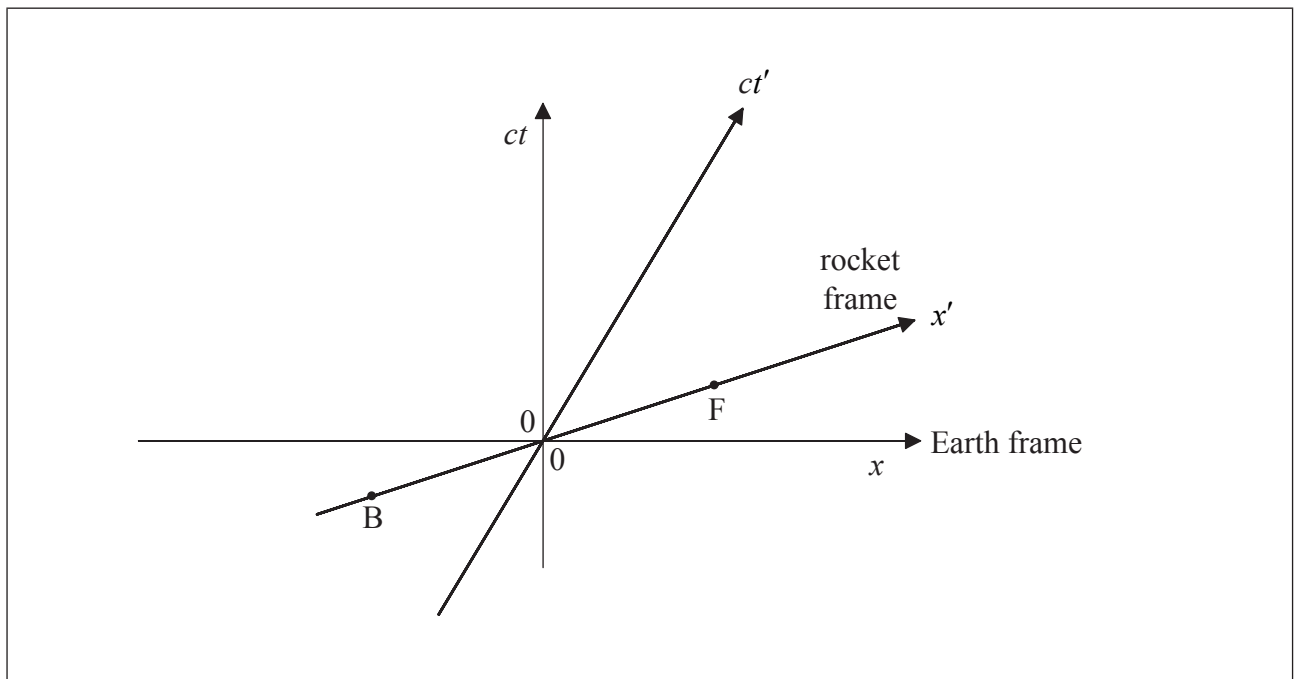

- (i) On the spacetime diagram, draw lines to show the worldlines of the photons from when they were emitted to when they were received. [3]

(Option A continues on the following page)

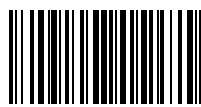

(Option A, question 5 continued)

- (ii) Using the spacetime diagram, determine which photon was emitted first according to observers in E. [2]

.....  
.....

- (iii) Determine the time separating the emissions of the two photons according to observers in E. [2]

.....  
.....  
.....  
.....

- (c) A missile is launched from the rocket. The velocity of the missile is  $-0.62c$  relative to the rocket. Calculate the velocity of the rocket relative to the Earth. [3]

.....  
.....  
.....  
.....

**End of Option A**



**Option B — Engineering physics**

6. A bucket of mass  $m$  is held above a water well by a rope of negligible mass, as shown. The rope is wound around a cylinder of mass  $M$  and radius  $R$ . The moment of inertia of the cylinder about its axis is  $I = \frac{1}{2}MR^2$ .

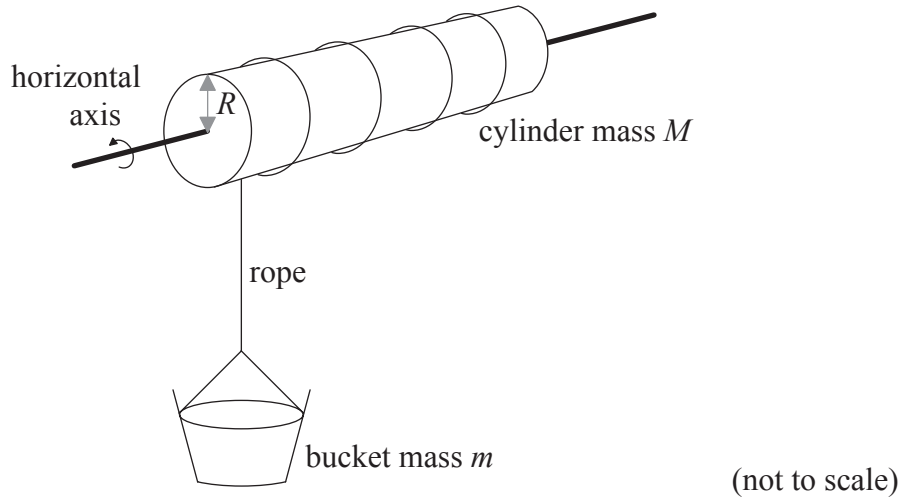

The bucket is released from rest. Resistance forces may be ignored.

- (a) Show that the acceleration  $a$  of the bucket is given by the following equation.

$$a = \frac{mg}{m + \frac{M}{2}} \quad [4]$$

.....

.....

.....

.....

.....

.....

*(Option B continues on the following page)*



(Option B, question 6 continued)

(b) The following data are available.

Bucket mass  $m = 24$  kg  
Cylinder mass  $M = 36$  kg  
Radius  $R = 0.20$  m

(i) Calculate the speed of the bucket when it has fallen a distance of 16 m from rest. [2]

.....  
.....  
.....  
.....

(ii) Calculate the rate of change of the angular momentum of the cylinder. [3]

.....  
.....  
.....  
.....

(c) The bucket in (b) is filled with water so its total mass is now 45 kg. The bucket is raised at a constant speed of  $2.0 \text{ m s}^{-1}$  using an electric motor attached to the cylinder. Calculate the power output of the motor. [1]

.....  
.....

(Option B continues on the following page)



(Option B continued)

7. The pressure volume ( $pV$ ) diagram shows a cycle ABCA of a heat engine. The working substance of the engine is a fixed mass of an ideal gas.

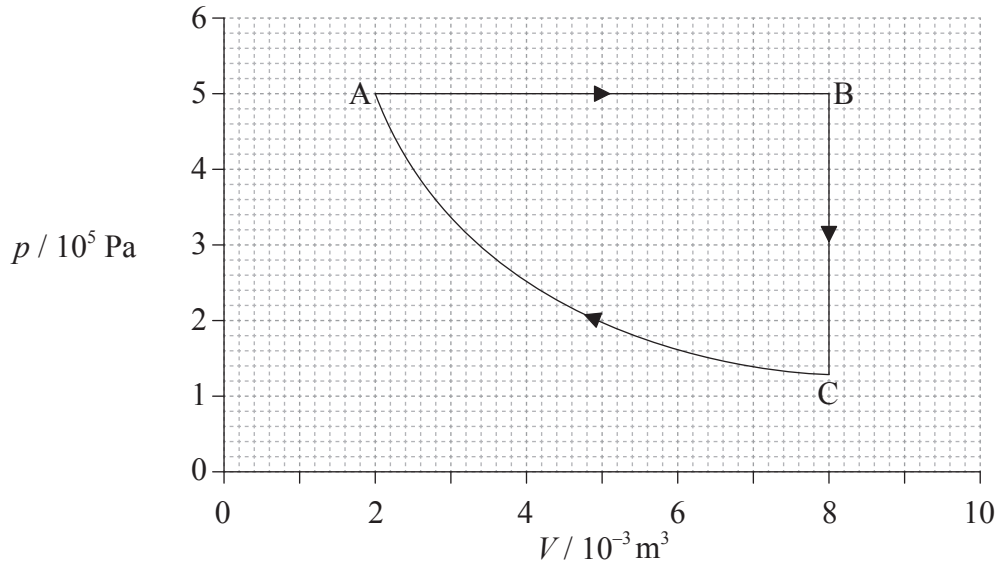

The temperature of the gas at A is 400 K.

- (a) Calculate the maximum temperature of the gas during the cycle. [1]

.....

.....

(Option B continues on the following page)





*(Option B, question 7 continued)*

(b) For the isobaric expansion AB, calculate the

(i) work done by the gas. [2]

.....  
.....  
.....  
.....

(ii) change in the internal energy of the gas. [1]

.....  
.....  
.....  
.....

(iii) thermal energy transferred to the gas. [1]

.....  
.....  
.....  
.....

*(Option B continues on the following page)*



(Option B, question 7 continued)

- (c) The work done on the gas during the isothermal compression is 1390J. Determine the change in entropy of the gas for this compression. [2]

.....  
.....  
.....  
.....

- (d) Determine the efficiency of the cycle ABCA. [2]

.....  
.....  
.....  
.....

- (e) State whether the efficiency of a Carnot engine operating between the same temperatures as those operating in cycle ABCA on page 14, would be greater than, equal to, or less than the efficiency in (d). [1]

.....

**End of Option B**



Please **do not** write on this page.

Answers written on this page  
will not be marked.



28EP17

Turn over

**Option C — Imaging**

8. (a) The diagram shows a Cassegrain reflecting telescope consisting of a small diverging mirror  $M_1$ , a large converging mirror  $M_2$ , and a converging lens  $L$ . The focal point of  $M_2$  is at  $F$ .

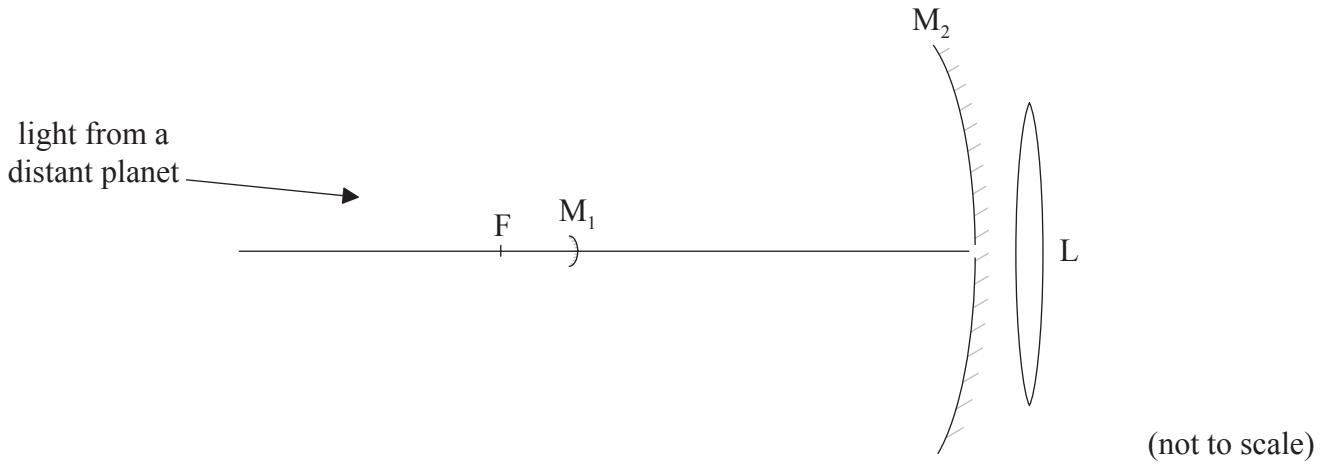

The telescope is used to view a planet. The diameter of the planet subtends an angle of  $1.40 \times 10^{-4}$  rad at  $M_2$ . The focal length of  $M_2$  is 9.50 m.

- (i) Show that the diameter of the image of the planet that would be formed by  $M_2$  alone is 1.33 mm. [3]

.....

.....

.....

.....

*(Option C continues on the following page)*

*(Option C, question 8 continued)*

- (ii)  $M_1$  is at a distance of 8.57 m from the aperture of  $M_2$ . The image in (a)(i) now serves as a virtual object for  $M_1$ . A real image is formed at the opening of  $M_2$ . Show that the diameter of this image is 12.0 mm. [3]

.....

.....

.....

.....

- (iii) The real image in (a)(ii) is now viewed by L of focal length 98.0 mm. The final image of the planet is formed at infinity. Calculate the overall magnification of the telescope. [3]

.....

.....

.....

.....

.....

.....

*(Option C continues on the following page)*



(Option C, question 8 continued)

- (b) (i) The large concave mirror in most reflecting telescopes is parabolic rather than spherical. Suggest **one** reason for this. [1]

.....  
.....

- (ii) State **one** advantage of reflecting telescopes compared to refracting telescopes. [1]

.....  
.....  
.....  
.....

- (c) Telescopes available today include, in addition to optical telescopes, infrared, radio, ultraviolet and X-ray telescopes. Outline how the introduction of these telescopes has changed our view of the universe. [2]

.....  
.....  
.....  
.....

(Option C continues on the following page)



(Option C continued)

9. (a) A compound microscope has an objective lens of focal length 0.40 cm and an eyepiece lens of focal length 3.20 cm. The image formed by the objective is 0.20 m from the objective lens. The final image is formed at a distance of 25 cm from the eyepiece lens.

(i) Show that the position of the object is  $4.1 \times 10^{-3}$  m from the objective lens. [1]

.....  
.....

(ii) Determine the angular magnification of the microscope. [2]

.....  
.....  
.....  
.....

(iii) The smallest distance between two points that can be distinguished by an unaided human eye from a distance of 25 cm is approximately 0.1 mm. Calculate the smallest distance between two points that can be distinguished using this microscope. [1]

.....  
.....

(Option C continues on the following page)



(Option C, question 9 continued)

- (b) The images from the microscope are digitized and transmitted along an optic fibre. The input power of the signal is 120 mW and the attenuation per unit length of the optic fibre is  $6.2 \text{ dB km}^{-1}$ . The length of the fibre is 4.6 km. Calculate the output power of the signal. [3]

.....

.....

.....

.....

.....

.....

**End of Option C**





**Option D — Astrophysics**

10. (a) State the element which is the end product of nuclear reactions taking place inside main sequence stars. [1]

.....

- (b) A main sequence star has apparent brightness  $7.6 \times 10^{-14} \text{ W m}^{-2}$  and luminosity  $3.8 \times 10^{27} \text{ W}$ .

- (i) Calculate, in pc, the distance of the star from Earth. [3]

.....  
.....  
.....  
.....

- (ii) Suggest whether the stellar parallax method is appropriate for measuring the distance to this star. [1]

.....  
.....

- (iii) The luminosity of the star in (b) is ten times the luminosity of our Sun.

Determine the ratio  $\frac{M}{M_{\odot}}$  where  $M_{\odot}$  is the mass of the Sun. [2]

.....  
.....  
.....  
.....

*(Option D continues on the following page)*



(Option D, question 10 continued)

(c) The image shows a Hertzsprung–Russell (HR) diagram.

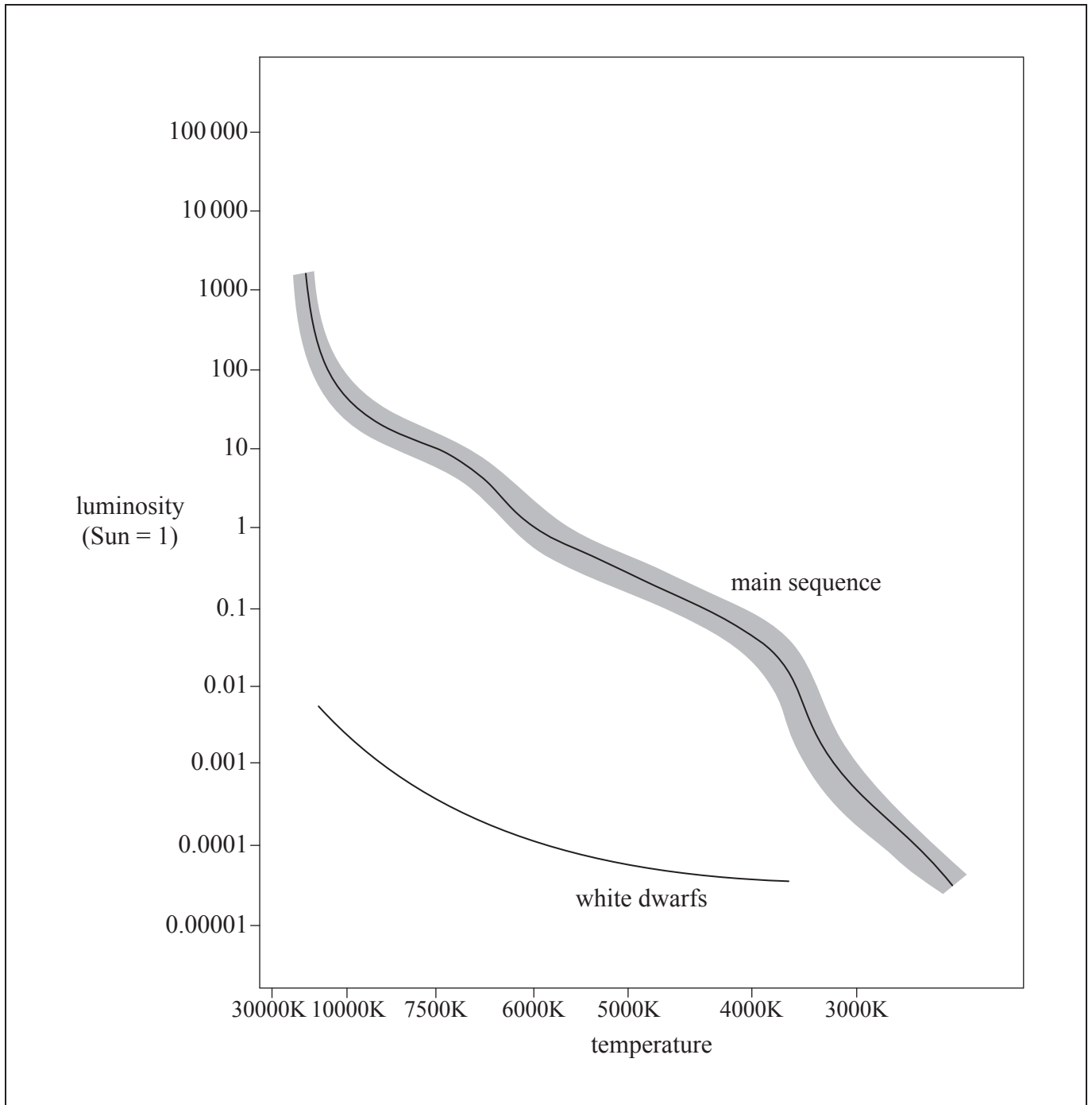

(Option D continues on the following page)



*(Option D, question 10 continued)*

- (i) Estimate, using the HR diagram, the ratio  $\frac{R}{R_{\odot}}$  where  $R$  is the radius of the star in (b) and  $R_{\odot}$  is the radius of the Sun. [3]

.....

.....

.....

.....

- (ii) Sketch a line on the HR diagram to show the evolutionary path of this star. [2]

- (iii) Describe, with reference to the Chandrasekhar limit, the equilibrium state of this star in its final evolutionary stage. [2]

.....

.....

.....

.....

*(Option D continues on the following page)*



*(Option D continued)*

11. (a) The hydrogen spectrum from a laboratory source includes a line of wavelength 434 nm. The same line emitted from a distant galaxy has wavelength 502 nm when observed on Earth.

(i) Suggest why the two wavelengths are different. [1]

.....

.....

(ii) Determine the distance, in Mpc, from this galaxy to Earth using a Hubble constant of  $71 \text{ km s}^{-1} \text{ Mpc}^{-1}$ . [2]

.....

.....

.....

.....

*(Option D continues on the following page)*



*(Option D, question 11 continued)*

(b) In the 1990s, two research groups started projects involving observations of distant supernovae. They aimed to show that distant galaxies were slowing down.

(i) Suggest why it was expected that distant galaxies would be slowing down. [1]

.....  
.....

(ii) Describe how it was deduced that the universe is expanding at an accelerated rate. [2]

.....  
.....  
.....  
.....

**End of Option D**

---



Please **do not** write on this page.

Answers written on this page  
will not be marked.



28EP28



# **MARKSCHEME**

## **SPECIMEN PAPER**

### **PHYSICS**

#### **Standard Level**

#### **Paper 3**

## General Marking Instructions

### Subject Details: Physics SL Paper 3 Markscheme

#### Mark Allocation

Candidates are required to answer **ALL** questions in Section A [**15 marks**] and all questions from **ONE** option in Section B [**20 marks**].  
Maximum total = [**35 marks**].

#### Markscheme format example:

| Question |   |    | Answers  | Notes                                 | Total |
|----------|---|----|--|---------------------------------------|-------|
| 4.       | b | ii | the displacement and acceleration ✓<br>are in opposite directions✓ | <i>Accept force for acceleration.</i> | 2     |

- Each row in the “Question” column relates to the smallest subpart of the question.
- The maximum mark for each question subpart is indicated in the “Total” column.
- Each marking point in the “Answers” column is shown by means of a tick (✓) at the end of the marking point.
- A question subpart may have more marking points than the total allows. This will be indicated by “**max**” written after the mark in the “Total” column. The related rubric, if necessary, will be outlined in the “Notes” column.
- An alternative wording is indicated in the “Answers” column by a slash (/). Either wording can be accepted.
- An alternative answer is indicated in the “Answers” column by “**OR**” on the line between the alternatives. Either answer can be accepted.
- Words in angled brackets < > in the “Answers” column are not necessary to gain the mark.
- Words that are underlined are essential for the mark.
- The order of marking points does not have to be as in the “Answers” column, unless stated otherwise in the “Notes” column.
- If the candidate’s answer has the same “meaning” or can be clearly interpreted as being of equivalent significance, detail and validity as that in the “Answers” column then award the mark. Where this point is considered to be particularly relevant in a question it is emphasized by **OWTTE** (or words to that effect) in the “Notes” column.
- Remember that many candidates are writing in a second language. Effective communication is more important than grammatical accuracy.



12. Occasionally, a part of a question may require an answer that is required for subsequent marking points. If an error is made in the first marking point then it should be penalized. However, if the incorrect answer is used correctly in subsequent marking points then **follow through** marks should be awarded. When marking, indicate this by adding **ECF** (error carried forward) on the script. “ECF acceptable” will be displayed in the “Notes” column.
13. Do **not** penalize candidates for errors in units or significant figures, **unless** it is specifically referred to in the “Notes” column.

SECTION A

| Question |   |     | Answers   | Notes  | Total |
|----------|---|-----|---|--|-------|
| 1.       | a | i   | $a = 330 \text{ } \langle \text{ms}^{-1} \rangle \checkmark$  |  | 1     |
|          | a | ii  | $b_{\text{max}} = \langle \frac{344 - 316}{40} \rangle = \langle 0.70 \text{ } \langle \text{ms}^{-1} \text{ } ^\circ\text{C}^{-1} \rangle \checkmark$<br>$b_{\text{min}} = \langle \frac{340 - 318}{40} \rangle = \langle 0.55 \text{ } \langle \text{ms}^{-1} \text{ } ^\circ\text{C}^{-1} \rangle \checkmark$<br>$\Delta b = \langle \frac{0.70 - 0.55}{2} \rangle = \langle 0.075 \approx \rangle \langle 0.08 \text{ } \langle \text{ms}^{-1} \text{ } ^\circ\text{C}^{-1} \rangle \checkmark$ |  | 3     |
|          | a | iii | $b = 0.59 (\pm 0.08) \text{ } \langle \text{ms}^{-1} \text{ } ^\circ\text{C}^{-1} \rangle \checkmark$   | <i>Allow 0.593 (<math>\pm 0.075</math>).</i> | 1     |
|          | b | i   | $\theta = \langle \frac{-330}{0.6} \rangle = \langle -550 \text{ } \langle ^\circ\text{C} \rangle \checkmark$   |  | 1     |
|          | b | ii  | temperature is unphysical<br><b>OR</b><br>there is no temperature below $-273^\circ\text{C}$<br><b>OR</b><br>this temperature cannot be right $\checkmark$<br>it appears that the linear fit model cannot be extrapolated far from $0^\circ\text{C}$ $\checkmark$   |  | 2     |

| Question |   | Answers  | Notes   | Total |
|----------|---|--|---|-------|
| 2.       | a | the estimated percentage uncertainty in $g$ is $2 \times 0.3 + 0.6 = 1\%$ ✓  | <i>Accept 1.2%.</i>   | 1     |
|          | b | use more than one height ✓<br>obtain $g$ from a suitable graph (of height $h$ versus $t^2$ ) ✓<br>$g$ is twice the gradient ✓<br><b>OR</b><br>use a smaller ball (to reduce air resistance) ✓<br>use a (much) larger height ✓<br>repeat many times (to get an average of time) ✓ | <i>Allow <math>h</math> versus <math>t^2</math> or <math>\sqrt{h}</math> versus <math>t</math> or <math>\log h</math> log <math>t</math>.</i><br><i>Analysis of <math>g</math> must fit quoted graph.</i> | 3     |
| 3.       | a | the actual specific heat capacity will be less than calculated value ✓<br>more thermal energy is transferred to the calorimeter and contents than accounted for ✓  | <i>Do not allow a bald answer.</i>  | 2     |
|          | b | metal may not have been heated uniformly<br><b>OR</b><br>metal may not all be at $100^\circ\text{C}$ ✓<br>energy was lost to air during the transfer ✓<br>energy may have been lost to the air through the calorimeter ✓<br>water may not be at uniform temperature ✓            |   | 1 max |

SECTION B

Option A — Relativity

| Question |   | Answers   | Notes  | Total |
|----------|---|---|--|-------|
| 4.       | a | Maxwell's equations implied a speed of light independent of its source<br><b>OR</b><br>in Newtonian mechanics, speed of light depends on velocity of source ✓<br><br>Einstein trusted Maxwell's equations<br><b>OR</b><br>Einstein modified Newtonian mechanics ✓ |  | 2     |
|          | b | i   | magnetic ✓   | 1     |
|          | b | ii  | if a force exists in one ⟨inertial⟩ frame a force must exist in any other ⟨inertial⟩ frame ✓<br>cannot be magnetic because the proton is at rest in $S'$ ✓ | 2     |
|          |   |   | <i>Accept discussion in terms of acceleration as equivalent to force.<br/>Accept an answer in terms of electric field.</i>                                 |       |

|    |   |    |  |   |
|----|---|----|--|---|
| 5. | a | i  | $\langle \frac{900}{c} \Rightarrow 3.0 \times 10^{-6} \langle s \rangle \checkmark$  | 1 |
|    | a | ii | $\gamma = \langle \frac{1}{\sqrt{1 - \frac{v^2}{c^2}}} = \frac{1}{\sqrt{1 - 0.64}} \Rightarrow \frac{5}{3} \approx 1.67 \checkmark$<br><br>$\Delta t = \langle \gamma \left[ \Delta t' + \frac{v \Delta x'}{c^2} \right] \Rightarrow \frac{5}{3} \left[ 3.0 \times 10^{-6} + \frac{0.80c \times 900}{c^2} \right] \checkmark$<br><br>$= 9.0 \times 10^{-6} \langle s \rangle \checkmark$ | 3 |

(continued...)

(Question 5 continued)

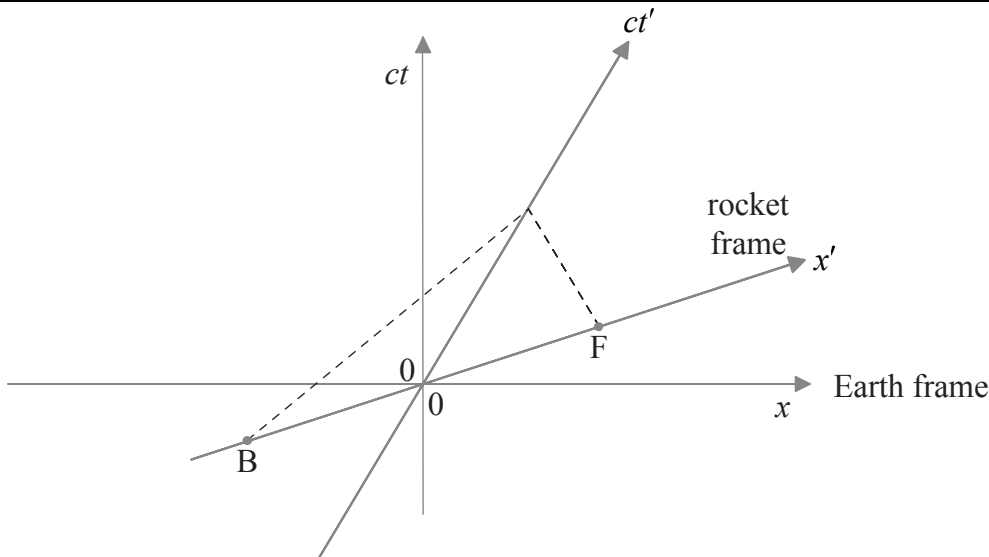
| Question |     | Answers   | Notes                | Total |
|----------|-----|---|----------------------|-------|
| a        | iii | $\Delta x = \langle ct = 3.0 \times 10^8 \times 9.0 \times 10^{-6} \Rightarrow 2700 \langle m \rangle$ <p><b>OR</b></p> $\Delta x = \langle \gamma [\Delta x' + v \Delta t'] \rangle = \frac{5}{3} \left[ 900 + 0.80c \times \frac{900}{c} \right] \Rightarrow 2700 \langle m \rangle \checkmark$ |                      | 1     |
| b        | i   |  <p>starting points at B and F ✓<br/>                     ending at the same point on the <math>ct'</math> axis ✓<br/>                     correct slope at <math>45^\circ</math> degrees ✓</p>                | <i>Judge by eye.</i> | 3     |

(continued...)

(Question 5 continued)

| Question |     | Answers  | Notes | Total |
|----------|-----|--|-------|-------|
| b        | ii  | <p>lines through B and F parallel to <math>x</math>-axis ✓<br/>to see that B happened first ✓</p>  |       | 2     |
| b        | iii | $\Delta t = \gamma \left[ \Delta t' + \frac{v\Delta x'}{c^2} \right] \Rightarrow \frac{5}{3} \left[ 0 + \frac{0.80c \times [900]}{c^2} \right] \checkmark$ $\Delta t = 4.0 \times 10^{-6} \text{ <s> } \checkmark$ |       | 2     |
| c        |     | <p>solving for <math>u</math> ✓<br/>correct substitution ✓<br/>correct answer of <math>0.36c</math> ✓</p>  |       | 3     |

Option B — Engineering physics

| Question |   | Answers  | Notes  | Total                                |   |
|----------|---|--|--|--------------------------------------|---|
| 6.       | a | $\alpha = \frac{a}{R} \checkmark$ $T \times R = \frac{1}{2} MR^2 \frac{a}{R} \checkmark$ $mg - T = ma \checkmark$ <p>⟨add equations/eliminate tension⟩ to get <math>mg = ma + \frac{1}{2} Ma \checkmark</math></p> |  | 4                                    |   |
|          | b | i  | $a = \left\langle \frac{24 \times 9.8}{24 + \frac{36}{2}} \right\rangle = 5.6 \langle \text{ms}^{-2} \rangle \checkmark$ $v = \langle \sqrt{2as} = \sqrt{2 \times 5.6 \times 16} \rangle = 13.4 \approx 13 \langle \text{ms}^{-1} \rangle \checkmark$ <p><b>OR</b></p> $mgh = \frac{1}{2} mv^2 + \frac{1}{2} I^2 \omega^2$ <p><b>OR</b></p> $mgh = \frac{1}{2} mv^2 + \frac{1}{2} I \frac{v^2}{R^2} \checkmark$ $v = \left\langle \sqrt{\frac{2 \times 24 \times 9.8 \times 16}{24 + 18}} \right\rangle = 13.4 \approx 13 \langle \text{ms}^{-1} \rangle \checkmark$ | Award [2] for a bald correct answer. | 2 |

(continued...)

(Question 6 continued)

| Question |    | Answers   | Notes  | Total |
|----------|----|---|--|-------|
| b        | ii | <p>rate of change of <math>L</math> is <math>I\alpha = I \frac{a}{R}</math> ✓</p> $\left\langle \frac{1}{2} MR^2 \frac{a}{R} \Rightarrow \frac{1}{2} \times 36 \times 0.20 \times \frac{24 \times 9.8}{24 + \frac{36}{2}} \right\rangle$ ✓<br>$= 20.2 \approx 20 \langle \text{N m} \rangle$ ✓<br><br><b>OR</b><br><br>rate of change of $L$ is $\Gamma$ (torque on axle) ✓<br>$\Gamma = TR = \frac{1}{2} \times 36 \times \frac{24 \times 9.8}{24 + \frac{36}{2}} \times 0.20$ ✓<br>$= 20.2 \approx 20 \langle \text{N m} \rangle$ ✓ | <p><i>Award [3] for a bald correct answer.</i></p> | 3     |
| c        |    | $\langle P = 45 \times 9.8 \times 2.0 \Rightarrow 882 \approx 880 \langle \text{W} \rangle$ ✓   |  | 1     |



| Question |   |     | Answers   | Notes   | Total |
|----------|---|-----|---|---|-------|
| 7.       | a |     | $\langle \text{maximum is at B and so } T_B = 400 \times \frac{8}{2} = \rangle 1600 \langle \text{K} \rangle \checkmark$                                    |   | 1     |
|          | b | i   | $W = \langle p\Delta V = \rangle 5.0 \times 10^5 \times [8.0 - 2.0] \times 10^{-3} \checkmark$<br>$W = 3.0 \times 10^3 \langle \text{J} \rangle \checkmark$ | <i>Award [2] for a bald correct answer.</i>   | 2     |
|          | b | ii  | $\Delta U = \langle \frac{3}{2} p\Delta V = \frac{3}{2} \times 3.0 \times 10^3 = \rangle 4.5 \times 10^3 \langle \text{J} \rangle \checkmark$               | <i>Award [1] for a bald correct answer.</i>   | 1     |
|          | b | iii | $Q = \langle \Delta U + W = 3.0 \times 10^3 + 4.5 \times 10^3 = \rangle 7.5 \times 10^3 \langle \text{J} \rangle \checkmark$                                | <i>Award [1] for a bald correct answer.</i>   | 1     |
|          | c |     | $\Delta S = \frac{Q}{T} = -\frac{1390}{400} \checkmark$<br>$\Delta S = -3.48 \approx -3.5 \langle \text{JK}^{-1} \rangle \checkmark$                        | <i>Award [1 max] for omitted minus sign.</i><br><i>Award [2] for a bald correct answer.</i> | 2     |
|          | d |     | $e = \frac{3000 - 1390}{7500} \checkmark$<br>$e = 0.21 \checkmark$  | <i>Award [2] for a bald correct answer.</i>   | 2     |
|          | e |     | greater $\checkmark$  |   | 1     |

**Option C — Imaging**

| Question |   |     | Answers  | Notes                         | Total |
|----------|---|-----|--|-------------------------------|-------|
| 8.       | a | i   | the image would be formed at the focal point of the concave mirror<br><b>OR</b><br>at a distance of 9.50 m from the centre of the concave mirror <since the object distance is very large> ✓<br>$\langle - \rangle \frac{9.50}{u} = \frac{D_i}{D_o}$ ✓<br>$D_i = 9.50 \times \frac{D_o}{u} = 9.50 \times \theta = 9.50 \times 1.40 \times 10^{-4}$ ✓<br>$= 0.00133 \langle \text{m} \rangle$ |                               | 3     |
|          | a | ii  | the object distance is $-[9.50 - 8.57] = -0.93 \langle \text{m} \rangle$ ✓<br>so the magnification is $\frac{8.57}{0.93} = 9.215$ ✓<br>the diameter of this image is then $9.215 \times 0.00133 = 0.012256 \langle \text{m} \rangle$ ✓   | <i>Ignore incorrect sign.</i> | 3     |
|          | a | iii | angle: $\frac{12.3 \langle \text{mm} \rangle}{98.0 \langle \text{mm} \rangle} = 0.126 \langle \text{rad} \rangle$ ✓<br>magnification: $\frac{0.126}{1.40 \times 10^{-4}}$ ✓<br>$= 900$ ✓   |                               | 3     |
|          | b | i   | with parabolic mirrors the problem of spherical aberration is eliminated ✓   |                               | 1     |

(continued...)

(Question 8 continued)

| Question |          |           | Answers  | Notes | Total        |
|----------|----------|-----------|--|-------|--------------|
|          | <b>b</b> | <b>ii</b> | no chromatic aberration ✓<br>easier/cheaper to make large mirrors than large lenses ✓<br>easier to support and so can be large ✓<br>less absorption in glass ✓   |       | <b>1 max</b> |
|          | <b>c</b> |           | a multitude of sources of EM radiation other than visible light have been discovered<br><b>OR</b><br>comparison of optical and non-optical images can be made ✓<br>thus vastly increasing our understanding of what exists in the universe ✓ |       | <b>2</b>     |

|           |          |            |   |  |          |
|-----------|----------|------------|---|--|----------|
| <b>9.</b> | <b>a</b> | <b>i</b>   | $\frac{1}{u} = \frac{1}{f} - \frac{1}{v} = \frac{1}{0.40 \times 10^{-2}} - \frac{1}{20 \times 10^{-2}} \checkmark$  |  | <b>1</b> |
|           | <b>a</b> | <b>ii</b>  | $M = \left\langle -\frac{v}{u} \times \frac{D}{f_e} \right\rangle = -\frac{0.20}{4.1 \times 10^{-3}} \times \frac{0.25}{3.2 \times 10^{-2}} \checkmark$<br>$M = 382.8 \approx 380 \checkmark$ |  | <b>2</b> |
|           | <b>a</b> | <b>iii</b> | $\frac{0.1 \langle \text{mm} \rangle}{380} \approx 260 \langle \text{nm} \rangle \checkmark$  |  | <b>1</b> |
|           | <b>b</b> |            | attenuation = $\langle 4.6 \times 6.2 \rangle = 28.5 \langle \text{dB} \rangle \checkmark$<br>$p = 120 \times 10^{-2.85} \checkmark$<br>power = $0.17 \langle \text{mW} \rangle \checkmark$   |  | <b>3</b> |

**Option D — Astrophysics**

| Question |   |     | Answers   | Notes   | Total |
|----------|---|-----|---|---|-------|
| 10.      | a |     | helium ✓  |   | 1     |
|          | b | i   | $d = \sqrt{\frac{3.8 \times 10^{27}}{4\pi \times 7.6 \times 10^{-14}}} \checkmark$ $d = 6.3 \times 10^{19} \text{ <m> } \checkmark$ $d = 2000 \text{ <pc> } \checkmark$                                   | <i>Award [3] for a bald correct answer.</i>       | 3     |
|          | b | ii  | no, the distance is too great for the parallax angle to be measured accurately <even from an orbiting telescope> ✓  |   | 1     |
|          | b | iii | $\left[ \frac{M}{M_{\odot}} \right]^{3.5} = 10 \checkmark$ $\frac{M}{M_{\odot}} = \langle 10^{\frac{1}{3.5}} \Rightarrow \rangle 1.93 \approx 2 \checkmark$   | <i>Award [2] for a bald correct answer.</i>       | 2     |
|          | c | i   | estimates of temperatures for star as 7500 (±200) <K> and Sun as 6000 <K> ✓<br>$10 = \frac{\sigma 4\pi R^2 7500^4}{\sigma 4\pi R_{\odot}^2 6000^4} \checkmark$ $\frac{R}{R_{\odot}} \approx 2 \checkmark$ | <i>Accept answers in the range of 1.9 to 2.1.</i> | 3     |
|          | c | ii  | line starting at correct position [ $T = 7500 \text{ K}, L = 10$ ] and extending into red giants ✓<br>ending at white dwarfs ✓  |   | 2     |

(continued...)

(Question 10 continued)

| Question |          |            | Answers  | Notes | Total    |
|----------|----------|------------|--|-------|----------|
|          | <b>c</b> | <b>iii</b> | equilibrium between gravitational pressure and electron degeneracy pressure ✓<br>provided final mass is below the Chandrasekhar limit/less than $1.4M_{\odot}$ ✓ |       | <b>2</b> |

|            |          |           |  |   |          |
|------------|----------|-----------|--|---|----------|
| <b>11.</b> | <b>a</b> | <b>i</b>  | the universe is expanding and so wavelengths <like all distances> are being stretched out<br><b>OR</b><br>wavelength increasing hence the Doppler redshift is being observed ✓   | <i>Must mention redshift in alternative answer.</i> | <b>1</b> |
|            | <b>a</b> | <b>ii</b> | $\langle z = \frac{v}{c} \Rightarrow \rangle v = 0.157 \times 3.0 \times 10^8 = 4.7 \times 10^4 \langle \text{km s}^{-1} \rangle$ ✓<br>$d = \langle \frac{v}{H} = \frac{4.7 \times 10^4}{71} \Rightarrow \rangle 660 \langle \text{Mpc} \rangle$ ✓ | <i>Award [2] for a bald correct answer.</i>         | <b>2</b> |
|            | <b>b</b> | <b>i</b>  | gravity is pulling back on the galaxies ✓  |   | <b>1</b> |
|            | <b>b</b> | <b>ii</b> | distant supernovae appeared less bright than expected ✓<br>indicating that they were further away than expected ✓  |   | <b>2</b> |